



F1522 - 1500lb Flake Ice Machine

Prodigy Plus® Flake Ice Machine



Features & Benefits

- Sealed, maintenance-free bearings for reduced preventative maintenance and long-lasting performance
- Stainless steel evaporator and auger for maximum durability
- AutoAlert™ indicator lights for better visibility
- Operational footprint among the industry's smallest
- Unit specific QR code for quick access to service manuals, cleaning guides and warranty history
- Front-breathing - No side clearance required for flexible placement
- Smart-Board™ advanced feature module available for additional diagnostic capabilities
- Optional Vari-Smart™ ice level control allows operators to customize ice levels
- Antimicrobial protection guards internal surfaces between cleanings
- Sealed refrigeration system minimizes outside airborne contamination
- Inherently more energy and water efficient than cube machines

F1522 - 1500lb Flake Ice Machine

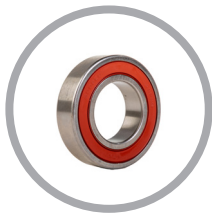

Sealed, maintenance-free bearings ensure maximum reliability and contribute to a long machine life



24 Hour Volume Production

Air Cooled			Remote Cooled		
70°F/21°C	Air	90°F/32°C	70°F/21°C	Air	90°F/32°C
50°F/10°C	Water	70°F/21°C	50°F/10°C	Water	70°F/21°C
1612/731		1088/494	1507/684		1206/547
lb/kg		lb/kg	lb/kg		lb/kg



Modular Bin Options

Model Number*	Dimensions W" x D" x H"	Bin Application		Ship Weight lb/kg
		Capacity lb/kg	Finish	
B948S	48 x 34 x 44**	893/406	Metallic	209/95
BH1100BB-A	48 x 34 x 50**	1100/499	SS w/ GBB†	280/127
BH1100SS-A	48 x 34 x 50**	1100/499	Stainless Steel	280/127
BH1300BB-A	60 x 34 x 50**	1400/635	SS w/ GBB†	310/140
BH1300SS-A	60 x 34 x 50**	1400/635	Stainless Steel	310/140
BH1600BB-A	60 x 34 x 62**	1755/796	SS w/ GBB†	370/168
BH1600SS-A	60 x 34 x 62**	1755/796	Stainless Steel	370/168

*Contact Scotsman for bin top requirements. **Add 6" Height for bin legs.
† Stainless steel with galvanized back & bottom.



AutoAlert™ indicator lights and QR code for easy maintenance



Flake Ice



Cools more quickly than other ice forms. Ideal for seafood and produce displays. Perfect for presentation and preservation.



Certification



Warranty

- 3 years parts and labor on all components.
- 5 years parts on the compressor.
- Warranty valid in North, South & Central America for commercial installations.
- Contact factory for warranty in other regions.
- Residential Applications: 1 year parts and labor



F1522 - 1500lb Flake Ice Machine

Prodigy Plus® Flake Ice Machine

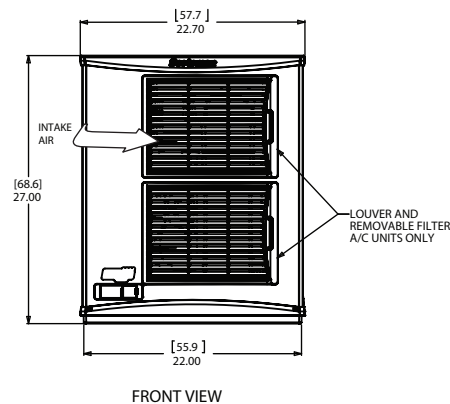
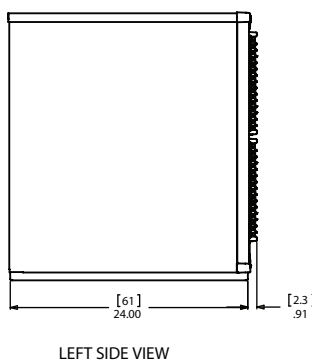
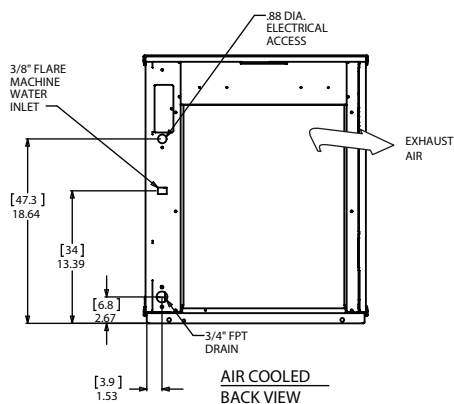
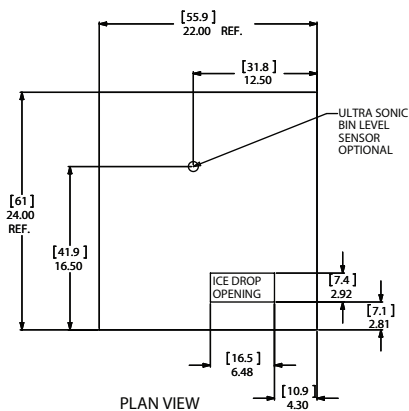

F1522 - 1500lb Flake Ice Machine



Specifications

Model Number	Condenser Unit	Basic Electrical Volts/Hz/Phase	Max. Fuse Size (amps)	Circuit Wires	Min. Circuit Ampacity	Energy Consumption kWh/100 lb (45.4 kg) 90°F(32°C)/70°F(21°C)	Water Usage Gallons/100 lb (liters/45.4 kg)	
							Potable 90°F(32°C)/70°F(21°C)	Condenser 90°F(32°C)/70°F(21°C)
FS1522A-32	Air	208-230/60/1	20	2	17.8	3.62	12.0/45.5	-
FS1522R-32	Remote	208-230/60/1	20	2	17.6	3.47	12.0/45.5	-



All Models

Dimensions (W x D x H):

Unit: **Individual**
22" x 24" x 27"
(55.9 x 61.0 x 68.6 cm)

Side by Side
45.8" x 24" x 27"
(116.3 x 61.0 x 68.6 cm)

Shipping Carton: 25.5" x 27.5" x 32.5"
(64.8 x 69.9 x 82.6 cm)

Shipping Weight: 224 lb / 102 kg
BTUs per hour: 16,000

Refrigerant: R-404A



Accessories

Model Number	Description
KVS	Vari-Smart™ Ice Level Control - Program ice bin levels to match ice needs.
KSBU	Smart-Board™ Advanced Control - Use additional operational data for fast diagnosis.
KSBU-N	Smart-Board™ Advanced Control with Network - Network capable.
KPAS	Prodigy Advanced Sustainability Kit - Includes KVS and KSBU - N

Scotsman recommends all ice machines have water filtration. See Scotsman water filter specification sheet for details.



Operating Requirements

	Minimum	Maximum
Air Temperatures	50°F (10°C)	100°F (38°C)
Water Temperatures	40°F (4.4°C)	100°F (38°C)
Remote Cond. Temps	-20°F (-29°C)	120°F (49°C)
Water Pressures	20 PSIG (1.4 bar)	80 PSIG (5.5 bar)
Electrical Voltage	-5%	+10%

Specifications and design are subject to change without notice.

an Ali Group Company



The Spirit of Excellence

Scotsman®

- 101 Corporate Woods Parkway, Vernon Hills, IL 60061
- 1-800-SCOTSMAN • Fax: 847-913-9844
- www.scotsman-ice.com • customer.relations@scotsman-ice.com

© 2020 Scotsman Ice Systems.

SIS-SS-PP-F1522 06-20