



BEVERAGE-AIR

Project: _____	AIA#
Item: _____	
Location: _____	SIS#
Approved: _____	

COUNTERTOP BLAST CHILLER

SB-031-RA-HC Self-Contained Blast Chiller/Freezer

**MODEL:
SB-031-RA-HC**

SB-031-RA-HC COUNTERTOP BLAST CHILLER

**3 Year Parts/Labor Warranty
5 Year Compressor Warranty**



CABINET CONSTRUCTION

- Stainless steel exterior and interior
- Slot-in type shelf supports made of stainless steel
- Cabinet features a core temperature probe to insert in the food to measure the blast chilling and freezing temperature (1 point core probe)
- LED controller
- Soft or hard blast chilling
- Soft or hard freezing
- Vertical ergonomic handle
- Rounded cell corners for easy cleaning
- Self-closing door with still position at 100°
- Unit comes standard with three (3) wire rod tray slides
- Shelf supports are adjustable in 1 1/2" to 3" centers
- Stainless steel wire rack structure, which provides excellent air circulation, minimizing the time required to blast chill the food
- HACCP alarm indicator

REFRIGERATION SYSTEM

- Self-contained refrigeration system uses R290 refrigerant to comply with all environmental concerns
- Copper-aluminum evaporating coil
- Easily accessible evaporator for proper maintenance
- Evaporator fitted with a high flow rate fan insures maximum cooling efficiency
- Automatic defrost and defrost water self evaporating
- Indirect air flow assures highest product quality
- Blast chilling (149°F to 50°F in 90 minutes) or shock freezing (149°F to 0°F in 240 minutes) cycles



Please verify qualifying units by visiting:
www.energystar.gov/cfs

3779 Champion Blvd., Winston-Salem, NC 27105
1-888-845-9800 Fax: 1-336-245-6453
Beverage-Air.com Sales@bevair.com



BEVERAGE-AIR

Countertop Self-Contained Blast Chiller/Freezer Model: SB-031-RA-HC

MODEL		SB-031-RA-HC
EXTERNAL DIMENSIONAL DATA		
Width Overall (in)		24.57"
Depth Overall (in)		27.6"
Height Overall (in)		23.62"
Number of Doors		1
Width, Door Opening (in)		48.03"
PERFORMANCE DATA		
Sheet Pan Capacity (12" x 20") (pans not included)		3 x GN 1/1
Chilling Capacity In 90 Min		17.6 lbs
Freezing Capacity In 240 Min		11 lbs
ELECTRICAL DATA		
Volume (ft ³ .)		7.1
Cabinet Voltage		115/60/1
Total Amperes		3.47
NEMA Plug		5-15P
REFRIGERATION DATA		
Refrigerant		R290
Refrigerant Amount (lbs/grams/ounces)		0.176 / 80 / 2.82
WEIGHT DATA		
Gross Weight - Crated		115 lbs
Height - Crated		28"
Width - Crated		26"
Depth - Crated		28"

We reserve the right to change specifications and product design without notice. Such revisions do not entitle the buyer to corresponding changes, improvements, additions or replacements for previously purchased equipment. Dimensional tolerances +/- 1/4". Metric dimensions (MM).

Model Views

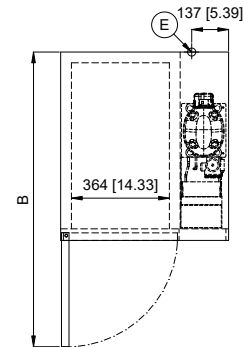

PLAN VIEW

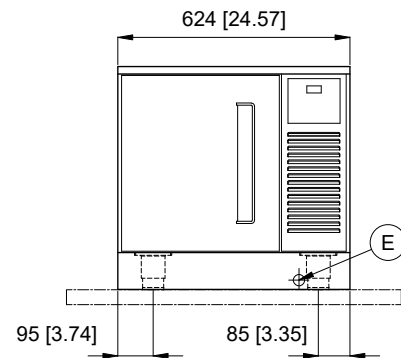

ELEVATION VIEW

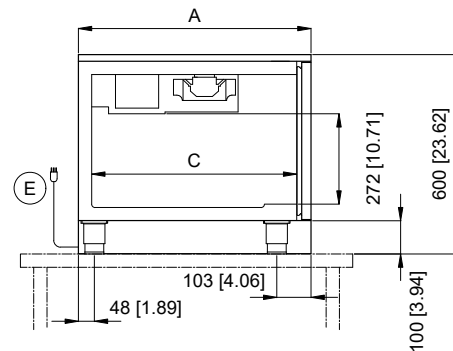

SIDE VIEW



115/60/1
NEMA 5-15P

ELECTRICAL CONNECTION

Unit pre-wired at factory and include 8' long cord and plug set.