



Equipment for the Foodservice Industry  
value + quality + service

## Stock Pot Ranges

RCTSP-18-1



### RCTSP-18-1

### Features

Features:

- Durable stainless steel structure that is corrosion resistant and easy to clean
- Extended top side walls to hold grates in place
- Highly efficient stainless steel burner, for maximum heat transfer
- Manually controlled valves for each burner, giving the ability to adjust and save energy
- Standby pilots for instant ignition
- Heavy duty cast iron top grates
- Adjustable stainless steel legs included
- Available in natural gas & propane

Warranty:

- One year limited warranty parts and labour

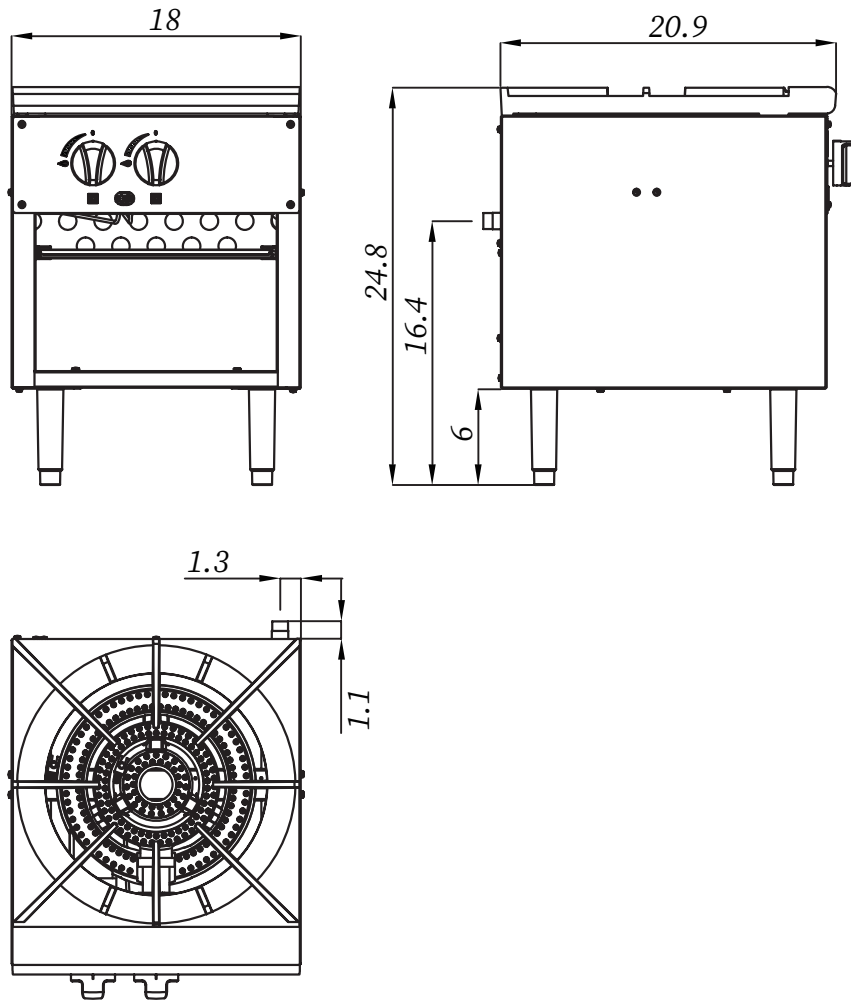

**RCTSP-18-1****Specifications**

Model	Burners	Ignition	Gas type	Intake-tube pressure (in.W.C.)	Per BTU B.T.U./h	Total BTU B.T.U./h	Nozzle No.	Net weight (LBS) rock
RCTSP-18-1-N	1	Manual	NG	4	40,000	80,000	#32	105.8
RCTSP-18-1-P			LP	10	40,000	80,000	#49	

*Specifications subject to change without notice.*