

efi sales Ltd.

Equipment for the Foodservice Industry
value + quality + service

Salamander

RCTSM-36



RCTSM-36

Features

Features:

- Durable stainless steel structure that is corrosion resistant and easy to clean
- Simple and reasonable
- Easy to maintain
- High efficient ceramic infrared burner, for quick and even heating
- Standby pilots
- Independent manual controls to save energy
- Mounting kits available to save kitchen space

Warranty:

- One year limited warranty parts and labour
- Specifications subject to change without notice



RCTSM-36

Specifications

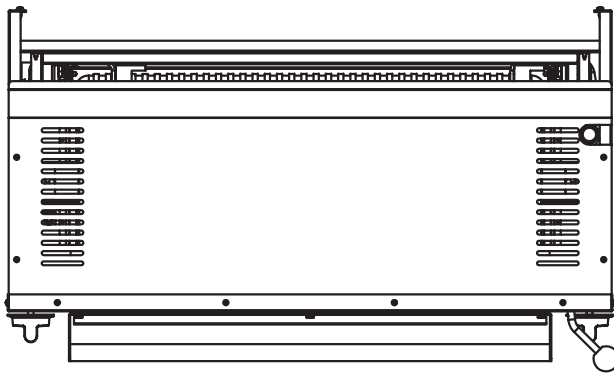
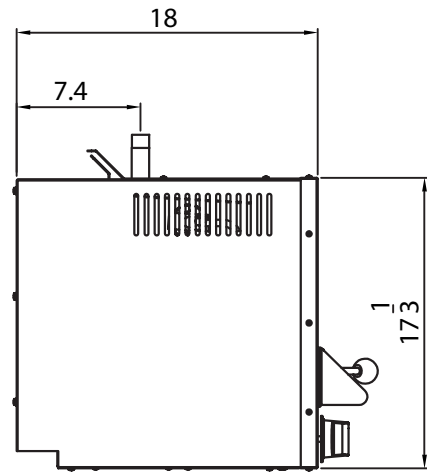
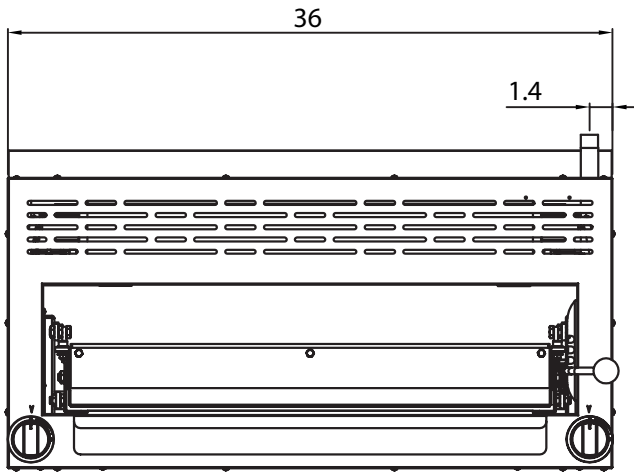

Model	Burners	Ignition	Gas type	Intake-tube pressure (in.W.C.)	Per BTU B.T.U./h	Total BTU B.T.U./h	Nozzle No.	Net weight (LBS) rock
RCTSM-36-N	2	Manual	NG	5	21,500	43,000	#47	143
RCTSM-36-P			LP	10	21,500	43,000	#54	