

**efi** sales Ltd.

Equipment for the Foodservice Industry  
value + quality + service

## Fryers

RCTFS-50



### RCTFS-50

### Features

#### Features:

- Durable stainless steel structure that is corrosion resistant and easy to clean
- Simple and robust structure, easy to manipulate and maintain
- All 304 stainless steel welded fryer tanks
- Heavy duty burners, with a stable flame, stand-by pilots
- Safety valve with an automatic voltage stabilizing function
- Imported high quality thermostat, temperature control between 93°C - 205 °C / 200°F - 400°F
- Self-reset high temperature limiting device
- Combination valve with built in pressure regulations
- Two nickel plated baskets includes wire mesh crumb screen
- Flue mounted basket hanger included
- 3/4" gas inlet located at rear of unit
- Oil cooling zone seated in the bottom of the tank to avoid the influence of food residue
- 1 1/4" drain valve for easy discharge
- Available in natural gas & propane
- One year limited warranty parts and labour

#### Warranty:

- One year limited warranty parts and labour



**RCTFS-50**

**Specifications**

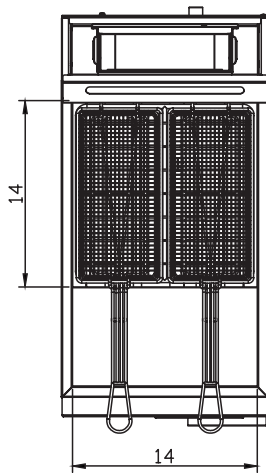
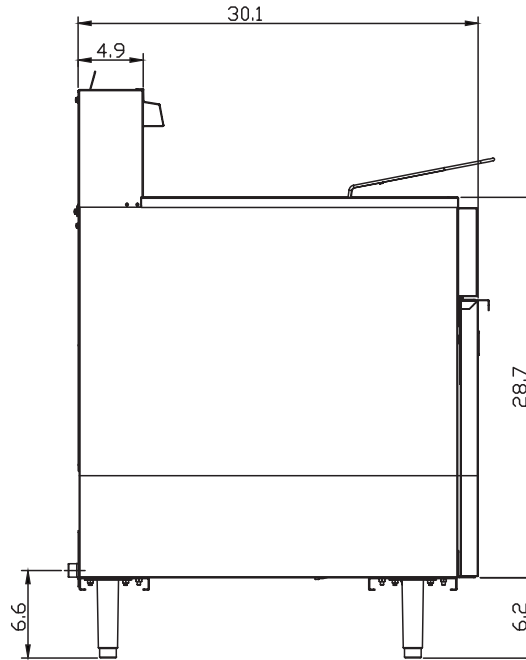
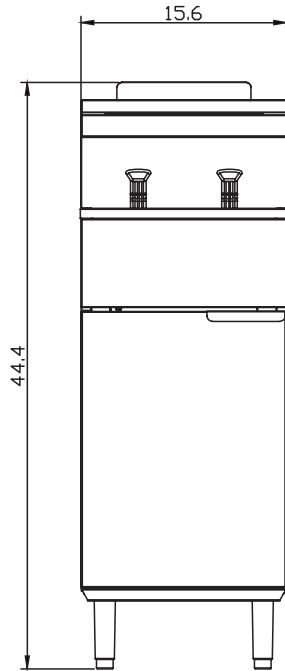

Model	Burners	Ignition	Gas type	Intake-tube pressure (in.W.C.)	Per BTU B.T.U./h	Total BTU B.T.U./h	Nozzle No.	Net weight (LBS) rock
RCTFS-50-N	4	Manual	NG	4	34,000	136,000	#36	145.3
RCTFS-50-P			LP	10	30,000	120,000	#52	

*Specifications subject to change without notice.*