



PR46B-D2

46" Pizza Prep Table with Drawers



PR46B-D2
08/04/23
Item # 13666

W x D x H

46" x 33.25" x 43.25"*
*to work surface with 4" casters



Item #: _____

Project: _____

Qty: _____

AIA#: _____

Features

- ▶ **Dual controller system for ideal temperatures in both rail and cabinet**
- ▶ **Improved airflow from back to front of the rail for more even cooling of all pans in the rail**
- ▶ **Night/Day Mode- when lid is open set point drops to keep food cool in rail; when lid is closed set point returns to normal so food can stay in rail overnight without freezing**



- Front-mounted removable air filter for easy maintenance
- Environmentally friendly R290 hydrocarbon refrigerant
- Stainless steel interior and exterior front, sides and top
- Solid state digital controller with temperature alarms and LED display (Fahrenheit or Celsius)
- Cabinet and drawers are insulated with 2" of CFC free, foamed in place polyurethane
- Drawer slides are constructed of 14 gauge stainless steel with acetal rollers
- Drawer frames are constructed of 16 gauge stainless steel and securely fastened to cabinet
- Drawers have a 250 lb. dynamic load rating
- Drawers will accommodate (2) 12" x 20" x 6" deep pans (pans by others)
- Provided with a full complement of polycarbonate plastic 1/3rd size pans, 4" deep and adapter bars
- Front breating air flow design
- Extruded aluminum flush mount drawer handle
- Magnetic drawer gasket is easily removable for cleaning
- 46" x 19" x 1/2" thick white polyethylene cutting board is standard
- Evaporator coils are epoxy electrocoated (E-Coat) to help fight corrosion
- Standard with 6" casters (two with brakes)
- 10 ft. cord and plug

If GFCI is required, a GFCI breaker MUST be used in lieu of GFCI receptacle

Dimensions / Capacity

Interior Storage Capacity (CF) (AHAM)

One-Section PR46B-D2

11.23ft³

Overall Width x Depth

46" x 33.25"

Height (including 6" casters)

43.25"

Depth with Cutting Board Installed (including 1" bumper)

36.25"

Depth with Drawer Fully Open (including 1" bumper)

57.5"

Pan Capacity (# of 1/3rd size x 4" deep)

6

Maximum Pan Depth

6"

Crated Weight

383 lbs.

Crated Length x Width x Height

48.75" x 34.75" x 45"

Electrical / Refrigeration

Voltage

115/60/1

HACR Breaker

15.0 Amps

Electrical Connection (NEMA)

5-15P Ⓢ

Voltage Range

104-126

Ambient Temp. Range

45° to 100°F

Control Setpoint Range

16° to 36°F (rail) / 28° to 40°F (cabin)

Amperage

4

Energy Consumption (kWh/day) @NSF

5.69

Heat Rejection (BTU/Hr.) @NSF

808

Approx. Nominal Compres. BTU/HR (HP)

2431(1/3HP)

Refrigerant / Charge Amount (oz)

R290 (2.4 oz)

Options

- 2" Casters
- 4" Casters

- Pan divider kit for rail
- Overshelves



Valid in United States, Canada, Puerto Rico and U.S. Territories. Contact factory for warranty in other countries.

Hoshizaki reserves the right to change specifications without notice.



PR46B-D2

46" Pizza Prep Table with Drawers



PR46B-D2
08/04/23
Item # 13666

FRONT VIEW

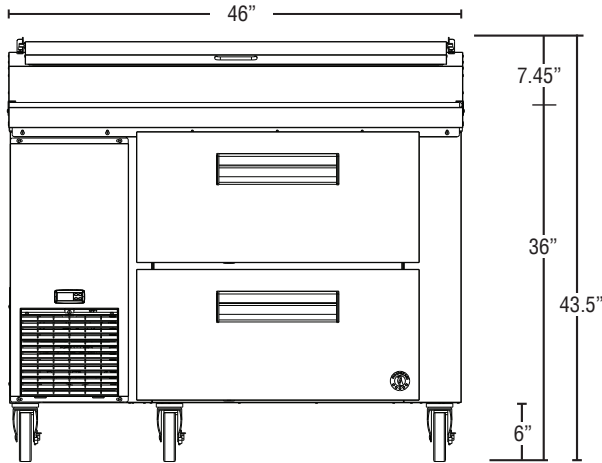

SIDE VIEW

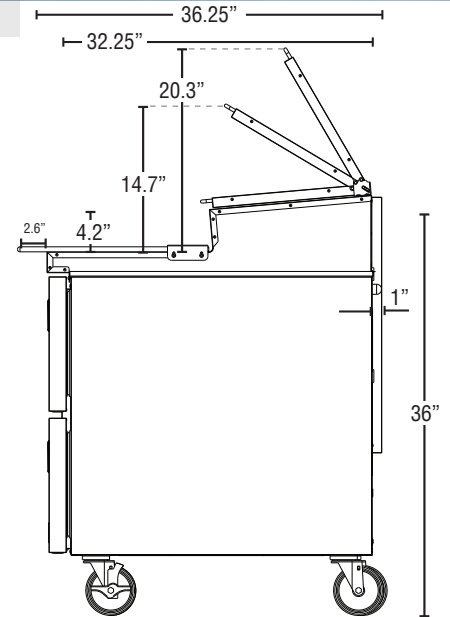

PLAN VIEW

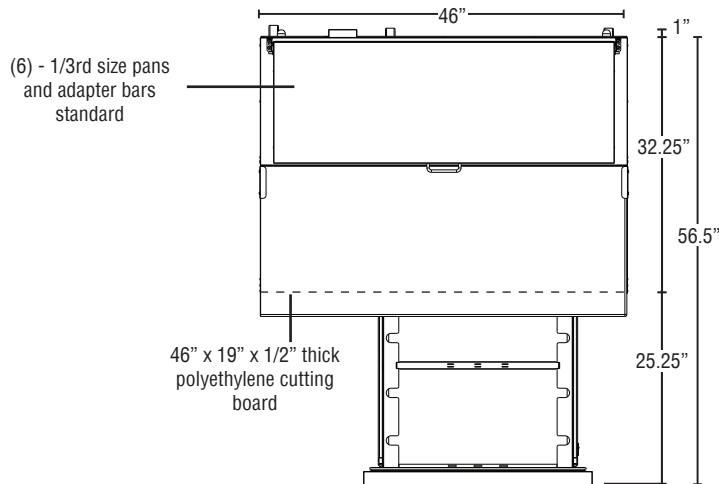

Cabinet Construction

The exterior cabinet top, front, and sides, are constructed of high quality stainless steel. The exterior back and bottom are constructed of coated steel. The cabinet interior back and sides are stainless steel with an ABS ceiling and stainless steel floor. Cabinet walls and drawers are insulated with 2" of foamed in place polyurethane. 6" polyolefin stem casters (two with brakes) are standard. The raised refrigerated rail is constructed of stainless steel interior and exterior (except back is galvanized steel). The rail is air cooled and utilizes a unique ducted air distribution system to distribute air evenly and maintain product temperature at safe levels. The rail will accommodate 1/6th, 1/3rd, 1/2 and full size pans 6" deep. Pans are located 1.5" below the front of the rail to assist in access to food product. An insulated, stainless steel, one piece hinged, lid is standard. Pizza preparation table is supplied with a 46" x 19" x 1/2" thick N.S.F. approved white polyethylene cutting board.

Drawer Construction

Drawer fronts are constructed of high grade stainless steel with stainless steel interior and are insulated with R290 CFC free foamed in place polyurethane. Each drawer accommodates (2) 12" X 20" X 6" deep pans (pans by others). Drawer frames are formed of 16 gauge stainless steel all welded construction and securely fastened in the cabinet. The drawer slides are constructed of 14 gauge stainless steel and durable acetal rollers with stainless steel ball bearings to prevent metal to metal contact. The drawer slides have a dynamic load capacity of 250 pounds and have been life-tested (fully-loaded) three hundred thousand cycles without showing significant wear. Drawers are provided with a one-piece extruded aluminum flush mount handle. Snap-in magnetic drawer gaskets are durable and easily removed for cleaning.

Refrigeration System

Front breathing refrigeration system allows unit to be built in to any enclosure with zero clearance at the side or rear. The high efficiency refrigeration system is self-contained with an epoxy electrocoated (E-Coat) evaporator coil for extended life. Condensate removal is accomplished with an energy efficient non-electric evaporation system. A capillary tube controls the flow of environmentally friendly R290 refrigerant through the evaporator. Unit uses a heated, time initiated defrost to eliminate any ice on the evaporator coil. An innovative ducted air distribution system distributes air evenly around food product in the rail. Engineered to maintain NSF-7 temperatures in 100°F ambient. (Certified to NSF-7 temperatures in 86°F ambient.) Pizza preparation tables are supplied with a full complement of N.S.F. approved polycarbonate plastic, 1/3rd size pans, 4" deep and stainless steel adapter bars. 115 volt units are equipped with a ten foot cord and NEMA rated plug (20.0 amps or less).