

PREMIUM SERIES

NSF-182-H

STAINLESS STEEL REACH-IN FREEZER

Ideal for commercial kitchens, restaurants & food processing spaces

NEW AIR
REFRIGERATION



FEATURES

Dixell™ digital temperature controller & on/off switch



Self-closing doors with stay open feature

Adjustable epoxy coated wire shelves



Stainless steel interior & exterior

Heavy duty caster with front brakes



T-RACK FITS 18" x 26" PANS

Food rack insert can be used with all refrigerator & freezer sizes

Product code: TRACK-1418-SS

SPECIFICATIONS

Capacity (Cu. ft)	64.8
Capacity (Litres)	1835
Exterior Unit Dimensions (in)	82.5" (w) x 32.5" (d) x 81.5" (h)
Interior Dimensions (in)	77" (w) x 27.5" (d) x 48.5" (h)
Packaging Dimensions (in)	84.25" (w) x 34.25" (d) x 85" (h)
Net/Gross Weight (lbs)	595/794
Doors	3
Adjustable Shelves	12
Shelf Dimensions	24" (w) x 24.5" (d) (left & right) 26.25" (w) x 24.5" (d) (center)
Casters	6 (3 with brakes)
Temperature	(0.5°C) - (5°C)
Ambiant Temperature	<38°C
Ambiant Humidity	65%
Refrigerant (CFC-Free)	R290
Input Power (W)	1300
Voltage	115V/60Hz
Amperage	16
Plug Type	NEMA 5-20P

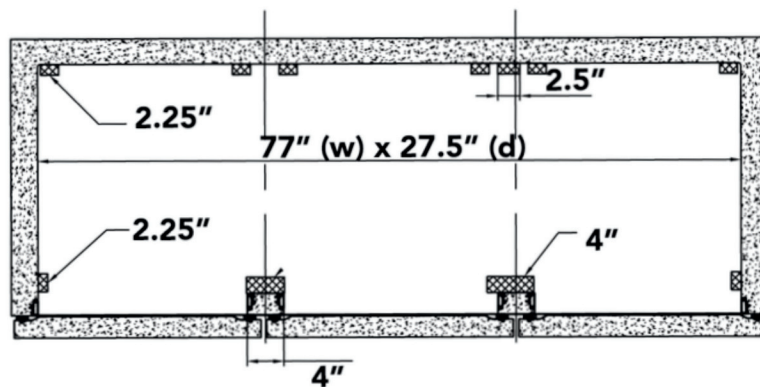
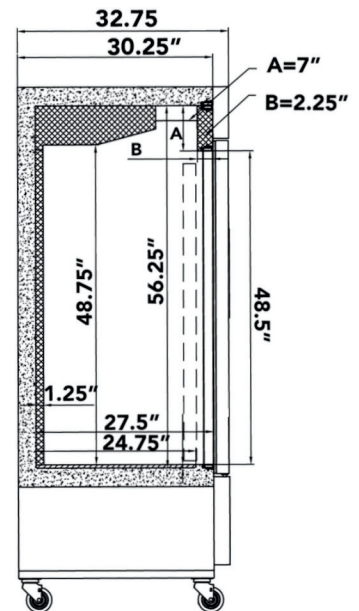
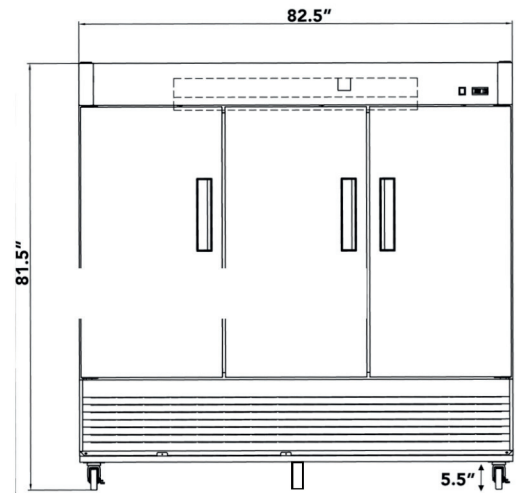

CUSTOMER SUPPORT



1-800-567-3620



NEWAIRREFRIGERATION.CA



NEW AIR

*Design and specifications can change without prior notice for product improvement