

NPT-29SA-2D



REFRIGERATED SALAD/SANDWICH PREP TABLE

Ideal for restaurants, cafeterias & food processing spaces



FEATURES

Stainless steel interior and exterior

Rear digital controller

Back mounted compressor

Clear plastic 1/6 pans included

14.5" deep cutting board



SPECIFICATIONS

Capacity (Cu. ft)	6.56
Capacity (Liters)	185.75 L
Exterior Dimensions (in)	29 1/8" × 33 1/8" × 43 5/8"
Package Dimensions (in)	33 3/8" × 35 7/8" × 48 3/8"
Net Weight (kg/lbs)	91.62 kg / 202 lbs
Drawers	2
Temperature Range (°C)	0.5 TO 5°C
Ambiant Temperature	25°C
Ambiant Humidity	55%
Refrigerant (CFC-Free)	R290
Amperage (A)	2 A
Voltage (V)	115V / 60Hz
Plug Type	NEMA 5-15P

Countertop storage

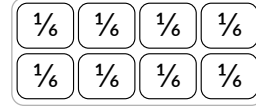

8 x 1/6 Pans

Top Drawer

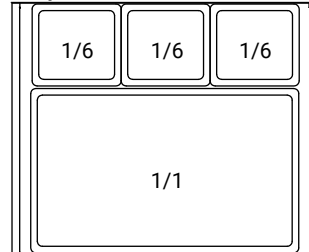

Bottom Drawer

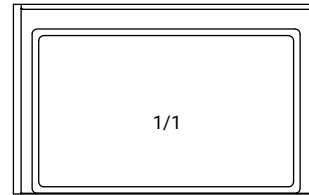

NEMA 5-15P

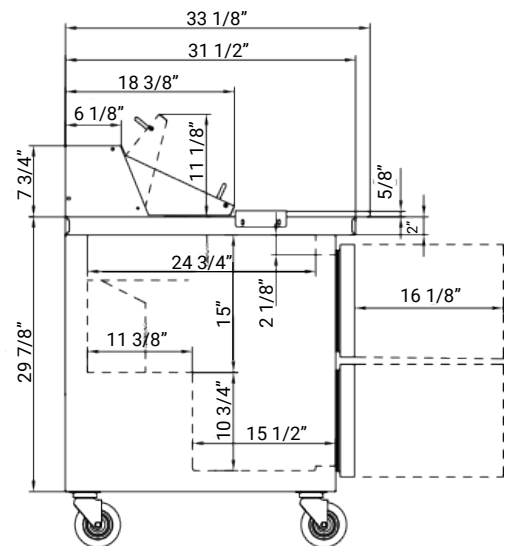
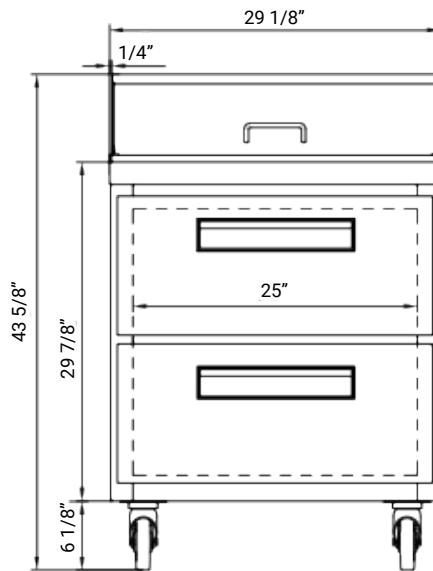

*Design and specifications may change without prior notice for product improvement

CUSTOMER SUPPORT



1-800-567-3620



NEWAIRREFRIGERATION.CA

