

# NGR-23-71H

## GLASS DOOR BEVERAGE MERCHANDISER

Ideal for cafés, grocery & convenience stores



**NEW AIR**  
REFRIGERATION



### FEATURES

Side LED interior lights



Black interior and exterior

Adjustable & removable  
epoxy-coated shelves



Low-E (energy-efficient low-emissivity)  
double tempered glass door

Self-closing door with lock



Casters & stabilizing feet

Mechanical temperature control

Rounded top corners

4 adjustable shelves

### OPTIONAL FEATURE



Additional shelves

# SPECIFICATIONS

Capacity (Cu. ft)	10.9
Capacity (Liters)	310
Exterior Dimensions (in)	23" (w) x 20.75" (d) 71.25" (h)
Interior Dimensions (in)	19.5" (w) x 16.25" (d) x 51.5" (h)
Packaging Dimensions (in)	24.25" (w) x 24.75" (d) x 75.25" (h)
Net Weight (kg/lbs)	59/130
Doors	1
Casters	4
Stabilizing Feet	2
Adjustable Shelves	4
Shelf Dimensions	19" (w) x 14" (d)
Temperature	(0°C) - (10°C)
Refrigerant (CFC-Free)	R600a
Amperage (A)	2
Voltage (V)	110V/60Hz
Plug Type	NEMA 5-15P

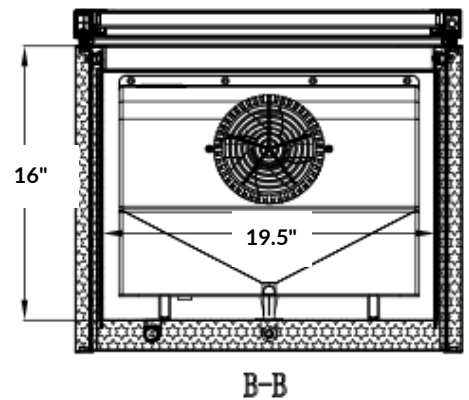
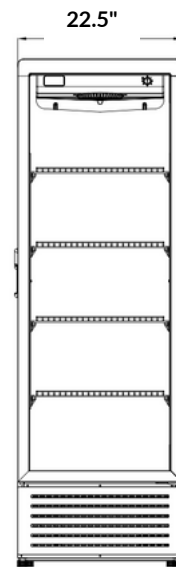
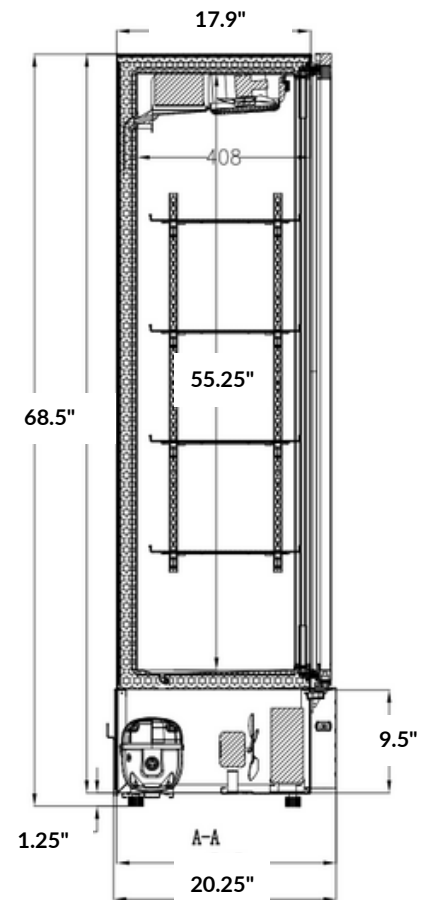

NEMA 5-15P



Intertek



**NEW AIR**

\*Design and specifications can change without prior notice for product improvement

CUSTOMER SUPPORT



1-800-567-3620



NEWAIRREFRIGERATION.CA

