



BEVERAGE-AIR®

Project: _____	AIA#
Item: _____	
Location: _____	SIS#
Approved: _____	

MMRF72HC GLASS DOOR MERCHANDISER SERIES - DUAL-TEMP

MARKETMAX DUAL TEMPERATURE REFRIGERATOR/FREEZER

MODEL:
MMRF72HC-1-B-BW

MMRF72HC Black Hinged Triple Glass Door

Hydrocarbon Series



7 Year Parts/Labor Warranty
7 Year Compressor Warranty

CABINET CONSTRUCTION

- Exterior features durable black painted steel
- Heavy duty interior construction includes white coated steel walls
- Brightly lit sign panel
- LED lighting
- Modern one-piece grille
- Full electronic control with digital display
- Dual-temp refrigerator/freezer units provide two different operating temperature zones for different types of products
- Self-contained bottom mount refrigeration system
- Left: refrigerator single section has double pane lowE glass door
- Right: freezer double section has triple pane lowE glass doors
- Self-closing doors with 120° stay-open feature
- Snap-in gaskets, easy to remove for cleaning or replacement
- Fifteen (15) heavy-duty epoxy coated wire shelves
- Four (4) shelf clips included per shelf
- Leveling feet standard

OPTIONS & ACCESSORIES

- White or stainless steel exterior
- Black or stainless steel interior
- Shelves black or white
- Stainless steel clips
- Flow track
- Gravity-Flo track
- Price tag molding
- 3" or 6" Casters
- 6" Legs or seismic/flanged legs
- Door locks (swing doors only)
- Custom signage & decals
- Remote option* (see note on back page)

REFRIGERATION SYSTEM

- Uses environmentally friendly, energy efficient R290 refrigerant, and meets all regulatory requirements for CARB, SNAP, DOE & more
- Adaptive defrost
- Epoxy coated evaporator coil
- Freezer maintains product temperature to -10°F
- Refrigerator maintains product temperatures between 36°F to 38°F



Please verify qualifying units by visiting:
www.energystar.gov/cfs

3779 Champion Blvd., Winston-Salem, NC 27105
1-888-845-9800 Fax: 1-336-245-6453
Beverage-Air.com Sales@bevair.com



BEVERAGE-AIR®

Dual-Temp Glass Door Merchandisers

Model: MMRF72HC-1-B-BW

MODEL	MMRF72HC-1-B-BW
EXTERNAL DIMENSIONAL DATA	
Width Overall	75"
Depth Overall (with handle)	33 ½"
Height Overall	78 ⅛"
Number of Doors	3
Depth with Door Open 90°	55 ½"
Door Openings (in)	21 ⅞" x 52 ¾"
INTERNAL DIMENSIONAL DATA	
NET Capacity (cubic ft.)	(R) 19.62 (F) 44.85
Internal Width Overall (in)	(R) 22" (F) 47"
Internal Depth Overall (in)	28 ½"
Internal Height Usable (in)	55"
Number of Shelves	15
ELECTRICAL DATA	
Full Load Amperes	(R) 2.88 (F) 10.0
Voltage	115/60/1
Nema Plug (8' cord)	(2) 5-15P
REFRIGERATION DATA	
Horsepower	(R) 1/4 (F) 3/4
Capacity (BTU/Hr)	(R) 1702 (F) 2772
Heat Rejection (BTU/Hr)	6711
Charge (lbs/grams/ounces)	(R) .1985 / 90 / 3.18 (F) .2094 / 95 / 3.35
SHIPPING DATA	
Gross Weight - Crated	842 lbs
Height - Crated	85"
Width - Crated	77"
Depth - Crated	36"

*NOTE: Remote units are field wired and come with 6" legs.
Refrigerant must be specified at time of order.

We reserve the right to change specifications and product design without notice. Such revisions do not entitle the buyer to corresponding changes, improvements, additions or replacements for previously purchased equipment. Dimensional tolerances +/- 1/4". Metric dimensions (MM).

Model Views

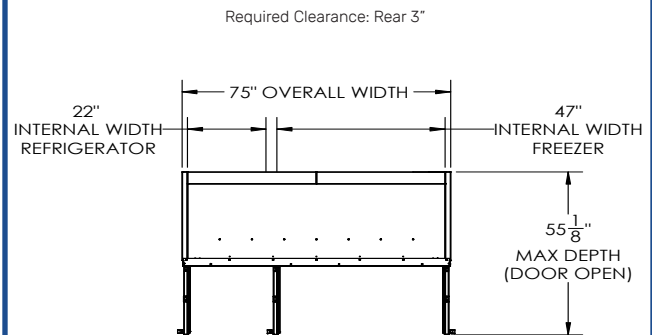

PLAN VIEW

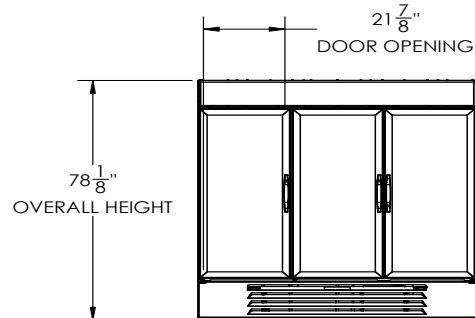

ELEVATION VIEW

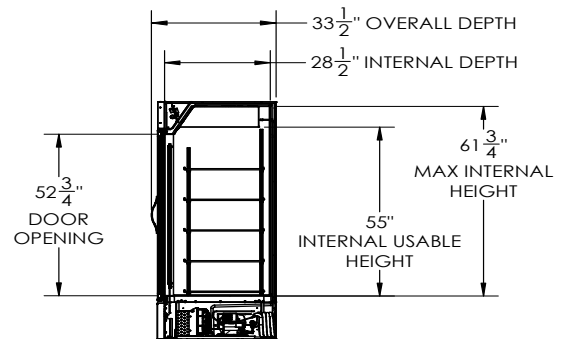

SIDE VIEW

ELECTRICAL CONNECTION



115/60/1
(2) NEMA 5-15P

Unit pre-wired at factory and include 8' long cord and plug set.

