

efi sales Ltd.

Equipment for the Foodservice Industry

value + quality + service

HOT DISPLAY CASE COUNTERTOP

14x26"

HCGS-CT-1426



HCGS-CT-1426

Features

Features:

- Brilliant internal LED illumination on top
- Adjustable temperature controller
- Temperature display
- Adjustable chrome plated shelves
- Back hinge door

Warranty:

- One year limited warranty parts and labour.
For full warranty details visit <https://www.efifoodequip.com/warranty-info.php>



HCGS-CT-1426

Specifications

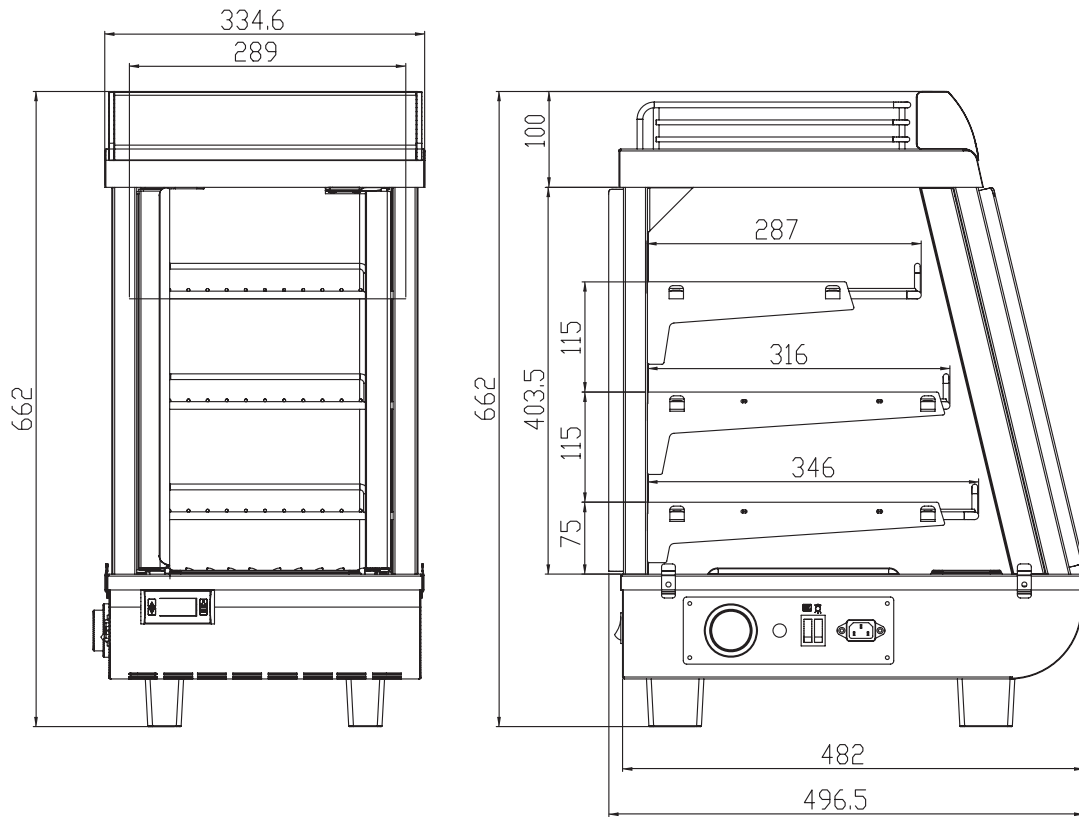

Model	Dimension (mm) (inch)			Voltage	Amps	Capacity (L) (Cu Ft.)	Net Weight (KG) (LBS)	Temperature Range
	L	D	H					
HCGS-CT-1426	345	484	662.5	115/60	7.6	76	21.2	30-90°C
	13.6	19.1	26.1			2.7	46.64	86-194°F

Equipped with one NEMA 5-15P plug 

Specifications subject to change without notice.