



**BEVERAGE-AIR®**

PROJECT: \_\_\_\_\_  
 ITEM # \_\_\_\_\_ QTY: \_\_\_\_\_  
 MODEL # \_\_\_\_\_  
 AIA # \_\_\_\_\_ SIS # \_\_\_\_\_  
 APPROVED: \_\_\_\_\_

**HORIZON BOTTOM MOUNT DUAL TEMP**

**Model: HBRF72HC-1-B**

**SOLID DOOR**

**7 YEAR WARRANTY  
 Parts, Labor, and Compressor**



**CABINET CONSTRUCTION**

- Stainless steel front, side, and grille (galvanized back & bottom)
- Stainless steel interior
- Full electronic control with one-touch defrost
- Dual temp refrigerator/freezer units provide two different operating temperature zones for different types of products
- Left: refrigerator single section , Right: freezer double section
- One-piece grille allows easy removal/installation for preventative maintenance
- Door locks (solid doors only)
- Self closing doors, 120° stay open feature with spring-loaded style hinges
- Snap-in magnetic door gaskets for easy cleaning and replacement
- Nine (9) heavy duty epoxy coated wire shelves
- LED lighting standard
- 6" Heavy-duty casters with (2) brakes
- Certified for open food product



**OPTIONS & ACCESSORIES**

- Epoxy shelves
- Shelf clips
- 3" Casters or 6" legs
- Wine temperature control
- Door swing orientation (at time of order)
- Remote option\* (see note on back page)

**REFRIGERATION SYSTEM**

- Uses environmentally friendly, energy efficient R290 refrigerant, and meets all regulatory requirements for CARB, SNAP, DOE & more
- Adaptive defrost
- Epoxy coated evaporator coil
- Refrigerator maintains product temperatures between 36°F to 38°F
- Freezer maintains product temperature to -10°F



# BEVERAGE-AIR®

## Horizon Bottom Mount Model: HBRF72HC-1-B

PLAN VIEW

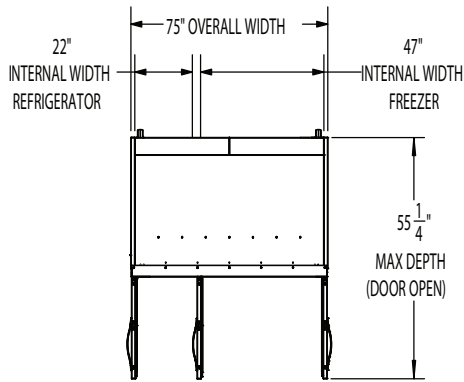

ELEVATION VIEW

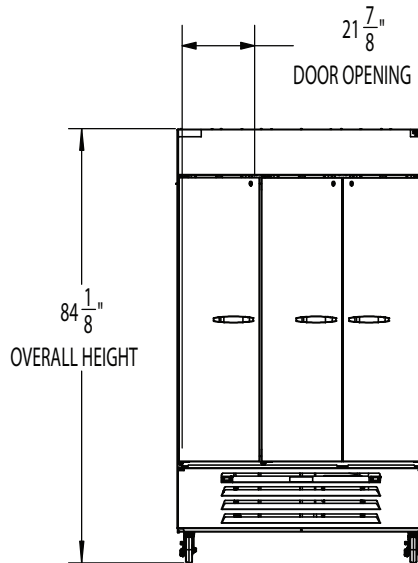

SIDE VIEW

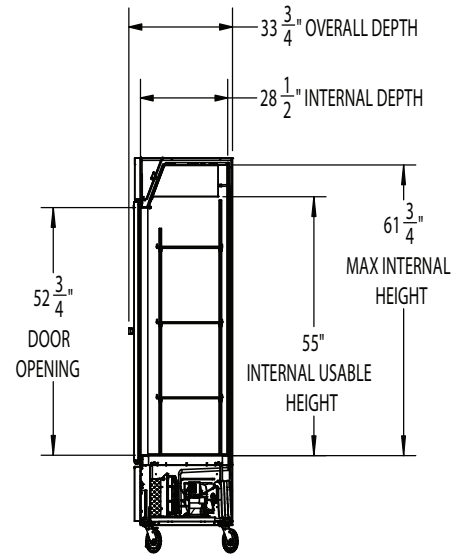

EXTERNAL DIMENSIONAL DATA	
Width Overall (in)	51 15/16"
Depth Overall (in)	33 9/16"
Height Overall (in)	83 15/16"
Number of Doors	2
Depth with Door Open 90° (in)	55 1/4"
Door Openings (in)	21 7/8" x 52 3/4"
INTERNAL DIMENSIONAL DATA	
NET Capacity (cubic ft.)	(R) 21.01 / (F) 21.01
Internal Width Overall (in)	(R) 22" (F) 47"
Internal Depth Overall (in)	28 1/2"
Internal Height Usable (in)	55"
Number of Shelves	10 (5 per section)

\*NOTE: Remote units are field wired and come with 6" legs. Refrigerant must be specified at time of order.

We reserve the right to change specifications and product design without notice. Such revisions do not entitle the buyer to corresponding changes, improvements, additions or replacements for previously purchased equipment. Dimensional tolerances +/- 1/4". Metric dimensions (MM).

Required Clearance: Bottom & Rear 3"

ELECTRICAL DATA	
Full Load Amps	(R) 2.88 (F) 10
Voltage	115/60/1
Nema Plug (8' cord)	(2) 5-15P
REFRIGERATION DATA	
Horsepower	(R) 1/4 (F) 3/4
Capacity (BTU/Hr)	(R) 1702 (F) 2772
Heat Rejection (BTU/Hr)	6711
Charge (lbs/grams/ounces)	(R) 0.1987 / 90 / 3.18 (F) 0.2094 / 95 / 3.35
SHIPPING DATA	
Gross Weight - Crated	790 lbs.
Height - Crated (in)	88"
Width - Crated (in)	77"
Depth - Crated (in)	45"

### ELECTRICAL CONNECTION



NEMA 5-15P

115/60/1  
NEMA (2) 5-15P

Unit pre-wired at factory and include 8' long cord and plug set.

3779 Champion Blvd., Winston-Salem, NC 27105 | 888-845-9800 | Fax: 336-245-6453 | Beverage-Air.com | Sales@bevair.com

Date Issued 1/26 | Printed in U.S.A.