



BEVERAGE-AIR®

PROJECT: _____
 ITEM # _____ QTY: _____
 MODEL # _____
 AIA # _____ SIS # _____
 APPROVED: _____

HORIZON BOTTOM MOUNT FREEZERS

Model: HBF35HC-1

SOLID DOOR



7 YEAR WARRANTY
Parts, Labor, and Compressor

CABINET CONSTRUCTION

- Stainless steel front, side, and grille (galvanized back & bottom)
- Stainless steel interior
- Full electronic control with one-touch defrost
- Door locks (solid doors only)
- One-piece grille allow easy removal/installation for preventative maintenance
- Self closing door with 120° stay open feature
- LED lighting
- Spring-loaded style hinges
- Plug-in magnetic door gaskets
- Six (6) heavy duty epoxy coated wire shelves
- 6" Casters with two (2) brakes



OPTIONS & ACCESSORIES

- 3" Casters or 6" legs
- Epoxy shelves
- Shelf clips
- Remote option* (see note on back page)

REFRIGERATION SYSTEM

- Uses environmentally friendly, energy efficient R290 refrigerant, and meets all regulatory requirements for CARB, SNAP, DOE & more
- Hot gas condensate evaporator
- Adaptive defrost
- Epoxy coated evaporator coil
- Freezer capable of maintaining product temperature down to -10°F



BEVERAGE-AIR®

Horizon Bottom Mount Model: HBF35HC-1

PLAN VIEW

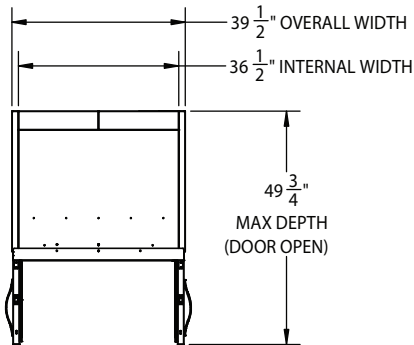

ELEVATION VIEW

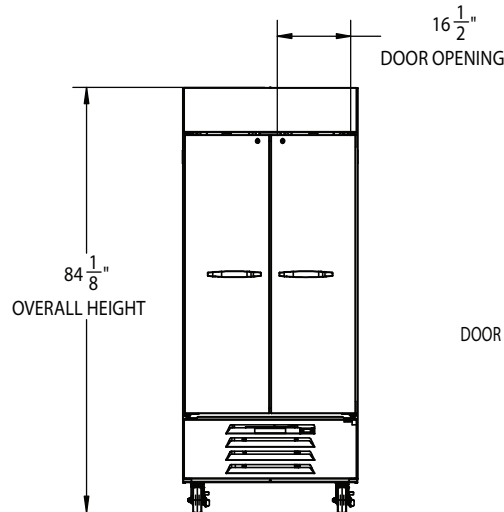

SIDE VIEW

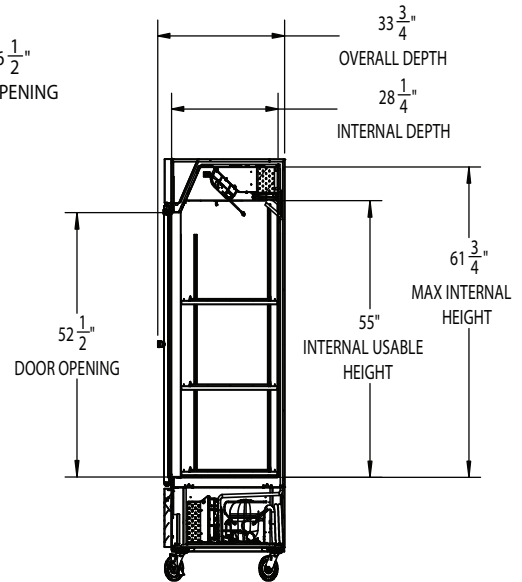

EXTERNAL DIMENSIONAL DATA	
Width Overall (in)	39 1/2"
Depth Overall (in)	33 7/8"
Height Overall (in)	84"
Number of Doors	2
Depth with Door Open 90° (in)	49 3/4"
Door Openings (in)	16 1/2" x 52 1/2"
INTERNAL DIMENSIONAL DATA	
NET Capacity (cubic ft.)	36.87
Internal Width Overall (in)	36 1/2"
Internal Depth Overall (in)	28 1/4"
Internal Height Overall (in)	61 3/4"
Number of Shelves	6

*NOTE: Remote units are field wired and come with 6" legs. Refrigerant must be specified at time of order.

We reserve the right to change specifications and product design without notice. Such revisions do not entitle the buyer to corresponding changes, improvements, additions or replacements for previously purchased equipment. Dimensional tolerances +/- 1/4". Metric dimensions (MM).

Required Clearance: Bottom & Rear 3"

ELECTRICAL DATA	
Full Load Amps	10.0
Voltage	115/60/1
Nema Plug (8' cord)	5-15P
REFRIGERATION DATA	
Horsepower	3/4
Capacity (BTU/Hr)	2772
Heat Rejection (BTU/Hr)	4158
Charge (lbs/grams/ounces)	0.2204 / 100 / 3.5
SHIPPING DATA	
Gross Weight - Crated	480 lbs.
Height - Crated (in)	86"
Width - Crated (in)	49"
Depth - Crated (in)	36"

ELECTRICAL CONNECTION



115/60/1
NEMA 5-15P

Unit pre-wired at factory and include 8' long cord and plug set.

3779 Champion Blvd., Winston-Salem, NC 27105 | 888-845-9800 | Fax: 336-245-6453 | Beverage-Air.com | Sales@bevair.com

Date Issued 1/26 | Printed in U.S.A.