



Equipment for the Foodservice Industry

value + quality + service

Work Top Freezer

FWDR2-60VC



FWDR2-60VC

Features

Features:

- Exterior & interior stainless steel construction
- Environmentally friendly R290 refrigerant
- Heavy duty Embraco compressor
- Self-closing and stay open door
- Efficient refrigeration system
- Recessed door handle
- Removable gasket that is easy to clean and replace
- Casters for easy movement
- Pre-installed shelves

Warranty:

- Two year parts and labour; Five years on compressor. For full warranty details visit <https://www.efifoodequip.com/warranty-info.php>



FWDR2-60VC Specifications

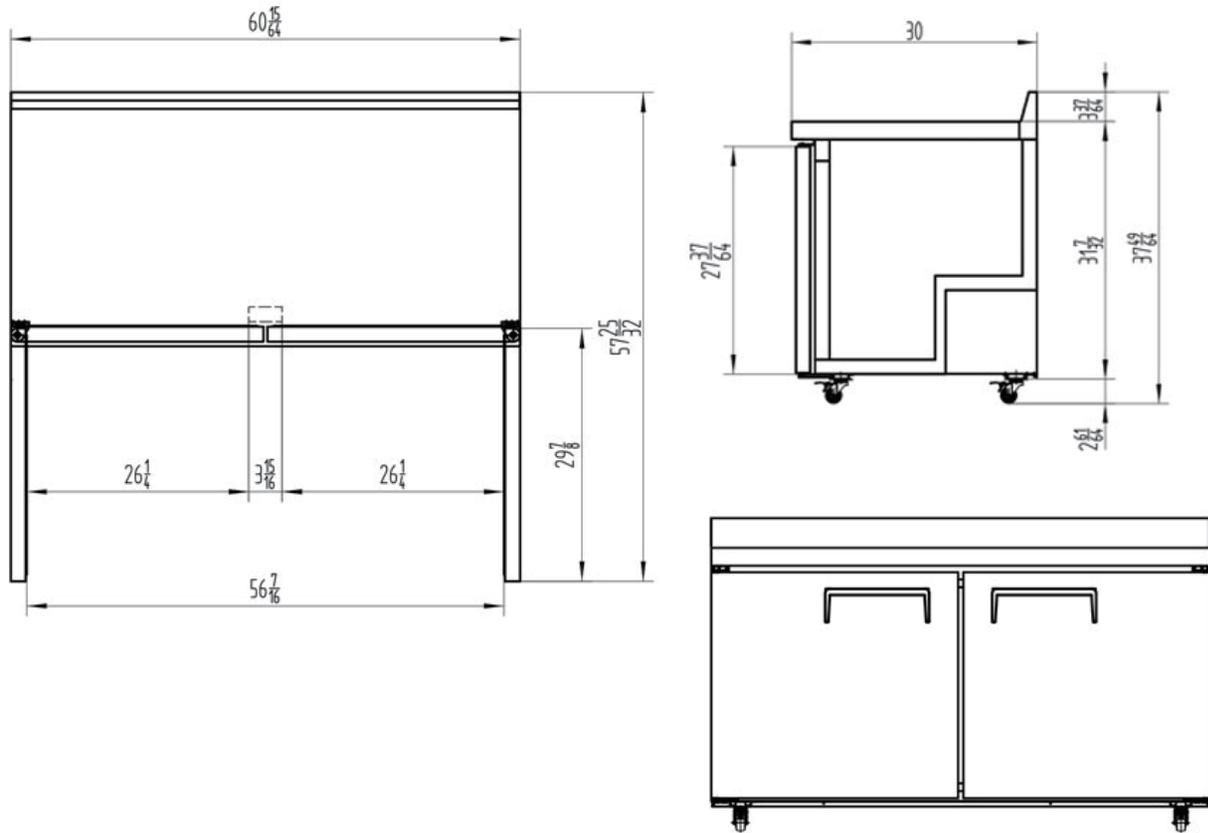

Model	Refrigerant	Doors	Shelves	Dimension (mm / inch)			HP	Voltage	Amps	Capacity (L / Cu Ft.)	Net Weight (KG / LBS)	Temperature Range
				L	D	H						
FWDR2-60VC	R290	2	2	1530	762	995	1/3	115/60	2.6	487	106	-8 ~ -1°F
				60.2	30.0	39.2				17.2	233	-22 ~ -18°C

Equipped with one NEMA 5-15P plug

Shipping Information

Crate Dimensions (mm / inch)			Net Weight (KG / LBS)	Gross Weight (KG / LBS)
L	D	H		
1585	831	1077	110	132
62.4	32.7	42.4	242	290

Specifications subject to change without notice.



EFI Sales Ltd.
Vancouver Office
26895 Gloucester Way
Langley, BC V4W 3Y3

EFI Sales Ltd.
Toronto Office
474 Attwell Drive
Toronto, ON M9W 5C3

Distribution Facilities:
Langley, BC
Toronto, ON

(604) 607-8850 Vancouver
(416) 798-7776 Toronto
(888) 565-9920 Toll Free
(604) 607-8820 Fax
info@efifoodequip.com