



Equipment for the Foodservice Industry

value + quality + service

## Work Top Freezer

FWDR2-48VC



### FWDR2-48VC

### Features

#### Features:

- Exterior & interior stainless steel construction
- Environmentally friendly R290 refrigerant
- Heavy duty Embraco compressor
- Self-closing and stay open door
- Efficient refrigeration system
- Recessed door handle
- Removable gasket that is easy to clean and replace
- Casters for easy movement
- Pre-installed shelves

#### Warranty:

- Two year parts and labour; Five years on compressor. *For full warranty details visit <https://www.efifoodequip.com/warranty-info.php>*



**FWDR2-48VC Specifications**

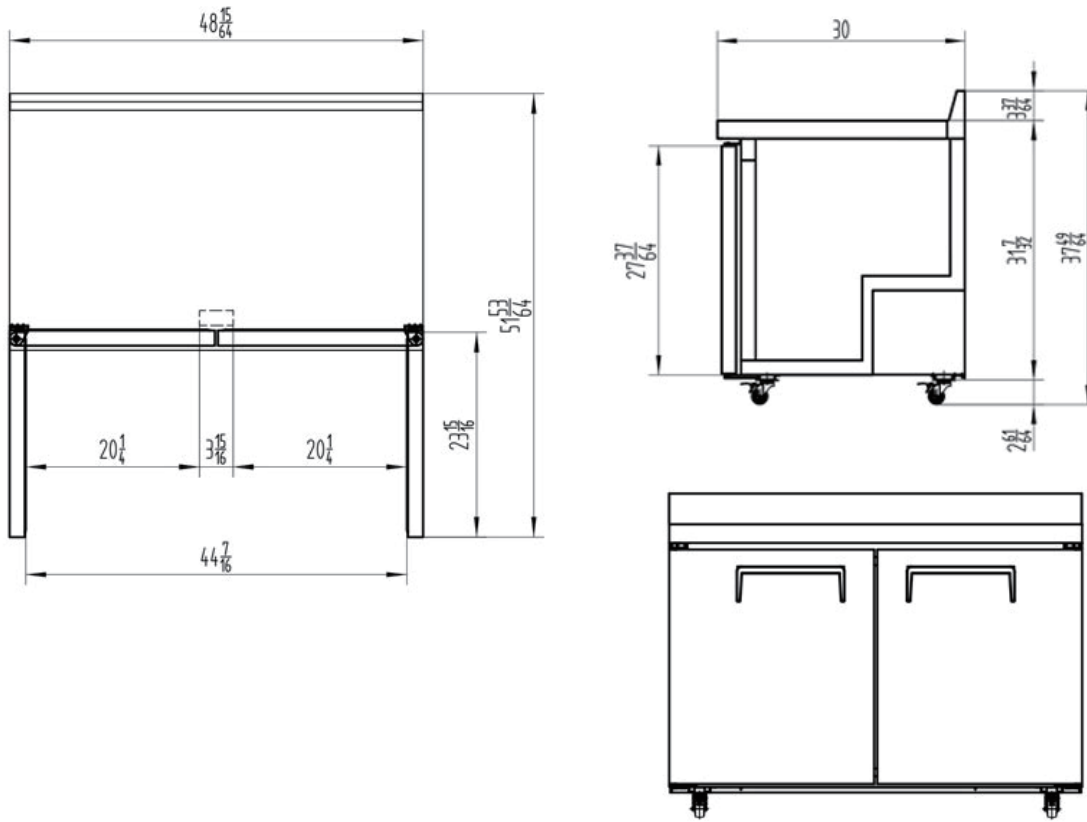

Model	Refrigerant	Doors	Shelves	Dimension (mm) (inch)			HP	Voltage	Amps	Capacity (L) (Cu Ft.)	Net Weight (KG) (LBS)	Temperature Range
				L	D	H						
FWDR2-48VC	R290	2	2	1225	762	995	1/3	115/60	2.6	379	94	-8 ~ -1°F
				48.2	30.0	39.2				13.4	207	-22 ~ -18°C

Equipped with one NEMA 5-15P plug

**Shipping Information**

Crate Dimensions (mm) (inch)			Net Weight (KG) (LBS)	Gross Weight (KG) (LBS)
L	D	H		
1280	831	1077	97	115
50.4	32.7	42.4	213	253

Specifications subject to change without notice.