



Equipment for the Foodservice Industry

value + quality + service

X-LINE Undercounter Freezer

FUDR2-48VCX



FUDR2-48VCX

Features

Features:

- Stainless steel interior and exterior, aluminum back
- Rounded corner design inside the cabinet for easy cleaning
- Self-closing swing door w/90°stay open feature
- Heavy duty recessed pull handles
- Adjustable/removable plastic coated wire shelves
- R290 refrigeration system holds -8°F to 0°F (-22°C to -18°C)
- Electronic control system makes it easy to adjust temperature set point and defrost frequency
- Casters with brakes for easy movement
- Easy to access condenser coil for cleaning and service

Warranty:

- Two year parts and labour; Five years on compressor. *For full warranty details visit <https://www.efifoodequip.com/warranty-info.php>*



FUDR2-48VCX Specifications

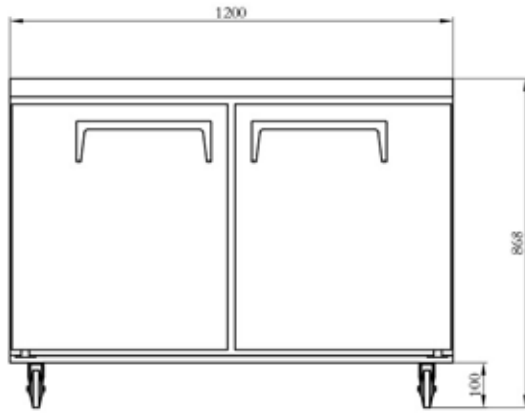

ELEVATION

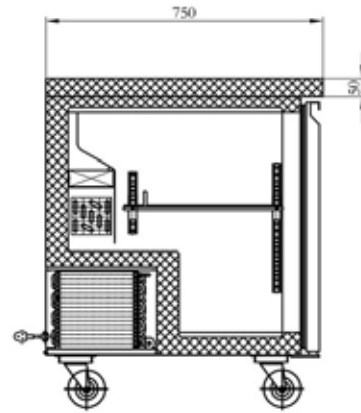

SECTION VIEW

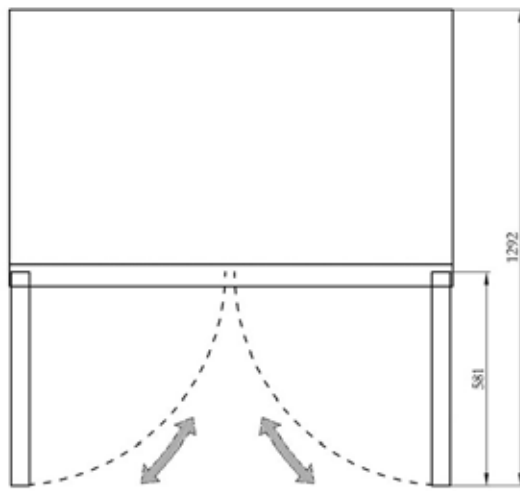

PLAN

Model	Refrigerant	Doors	Shelves	Dimension (mm) (inch)			HP	Voltage	Amps	Capacity (L) (Cu Ft.)	Net Weight (KG) (LBS)	Temperature Range
				L	D	H						
FUDR2-48VCX	R290	2	2	1200	750	868	1/3	115/60	4.5	338	92	-8 ~ 0°F
				47.2	29.5	34.1				12	202	-22 ~ -18°C

Specifications subject to change without notice.