



Equipment for the Foodservice Industry

value + quality + service

## Novelty Refrigeration

FCCG-39



### FCCG-39

### Features

#### Features:

- Durable white powder coated steel exterior with white precoated steel interior
- Temperature display
- PVC coated baskets included
- Sliding doors with curved top glass for easy access
- Built in lock to secure products
- Eco-friendly R-290 refrigerant
- Low profile casters with locks

#### Warranty:

- One year limited warranty parts and labour
- Specifications subject to change without notice



**FCCG-39**

**Specifications**

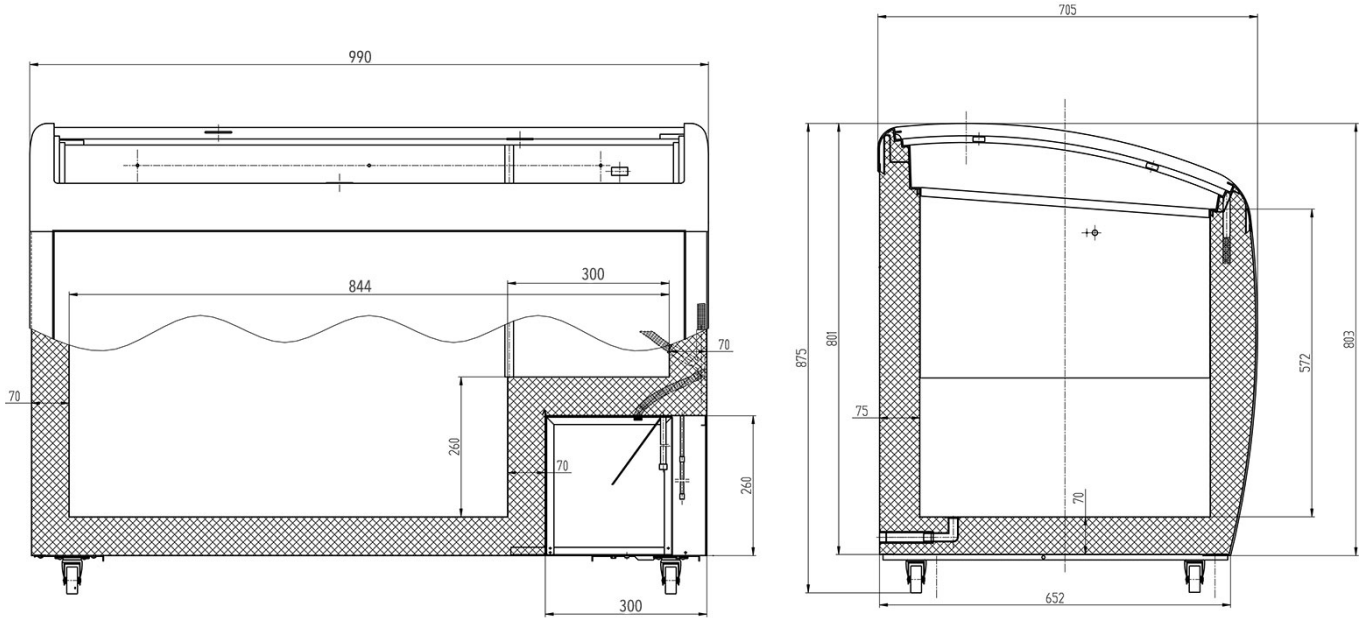

Model	Baskets	Dimension (mm) (inch)			HP	Voltage	Amps	Capacity (L) (Cu Ft.)	Net Weight (KG) (LBS)	Temperature Range	NEMA Config.
		L	D	H							
FCCG-39	2	990	705	875	1/3+	115/60/1	3.5	260.5	64	≤ -26°C	5-15A
		38.9	27.8	34.5				9.2	141	≤ -15°F	