



Equipment for the Foodservice Industry  
value + quality + service

## COUNTERTOP REFRIGERATED FREEZERS

F1-98GDCT



### F1-98GDCT

### Features

Features:

- Countertop series
- Glass design for maximum product visibility;
- Attractive, black exterior with white interior
- Adjustable temperature to keep different beverage
- LED interior lighting
- Shelves installed

- Lock installed

Warranty

- 2 year parts and labour; 5 years on compressor
- Specifications subject to change without notice



**F1-98GDCT**

**Specifications**

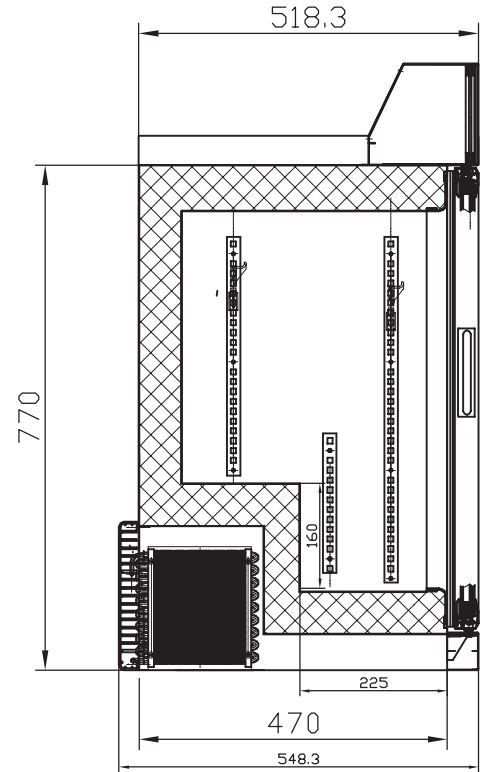
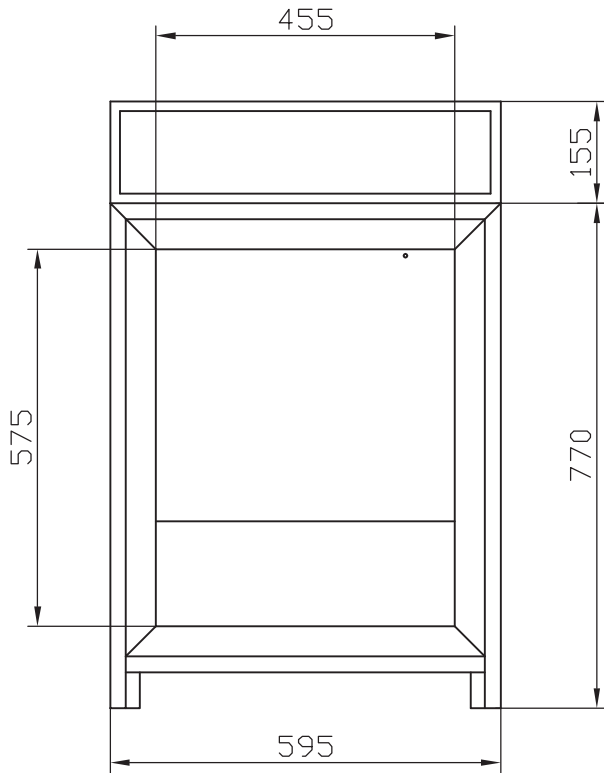

Model	Size (WxDxH) mm	Inner tank size (WxDxH) mm	Net Weight (kg/Lbs)	Gross Weight (kg/Lbs)	Capacity (L/Cu.ft)	Voltage(V)	Current (A)	Temperature Range	Light box or not
F1-98GDCT	595*570*955	455*405*415	50	60	98	110V 60HZ	4	-25~10°C	Yes
	23.4*22.4*37.6	17.9*15.9*16.3	110	132	3.5	110V 60HZ			