



Equipment for the Foodservice Industry

value + quality + service

## Work Top Refrigeration

CWDW2-60VC



### CWDW2-60VC

### Features

#### Features:

- Exterior & interior stainless steel construction
- Heavy duty Embraco compressor
- Self-closing and stay open door
- Efficient refrigeration system
- Recessed door handle
- Removable gasket that is easy to clean and replace
- Casters for easy movement
- Pre-installed shelves

#### Warranty:

- Two year parts and labour; Five years on compressor
- Specifications subject to change without notice



**CWDW2-60VC Specifications**

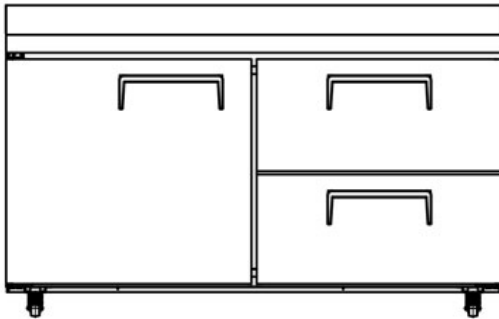
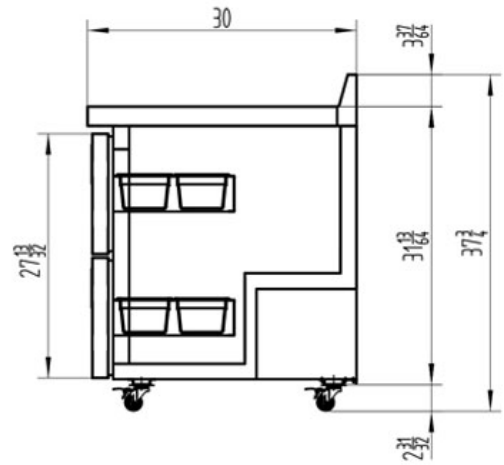
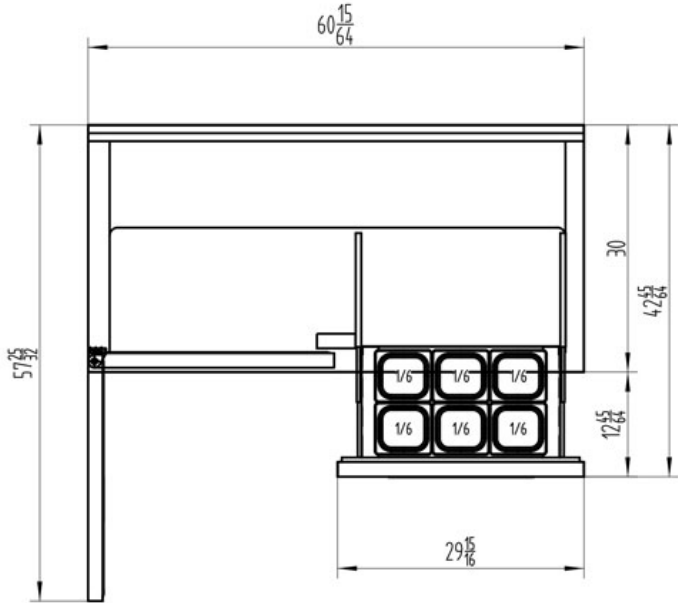

Model	Refrigerant	Doors	Shelves	Dimension (mm) (inch)			HP	Voltage	Amps	Capacity (L) (Cu Ft.)	Net Weight (KG) (LBS)	Temperature Range
				L	D	H						
CWDW2-60VC	R134a	1	1	1530	762	995	1/4	115/60	4.2	506	135	1 ~ 8°C
				60.2	30.0	39.2						17.9