



Equipment for the Foodservice Industry

value + quality + service

## Work Top Refrigeration

CWDR1-27VC-L



### CWDR1-27VC-L Features

#### Features:

- Exterior & interior stainless steel construction
- Environmentally friendly R290 refrigerant
- Heavy duty Embraco compressor
- Self-closing and stay open door
- Efficient refrigeration system
- Recessed door handle
- Removable gasket that is easy to clean and replace
- Casters for easy movement
- Pre-installed shelves

#### Warranty:

- Two year parts and labour; Five years on compressor. For full warranty details visit <https://www.efifoodequip.com/warranty-info.php>



**CWDR1-27VC-L Specifications**

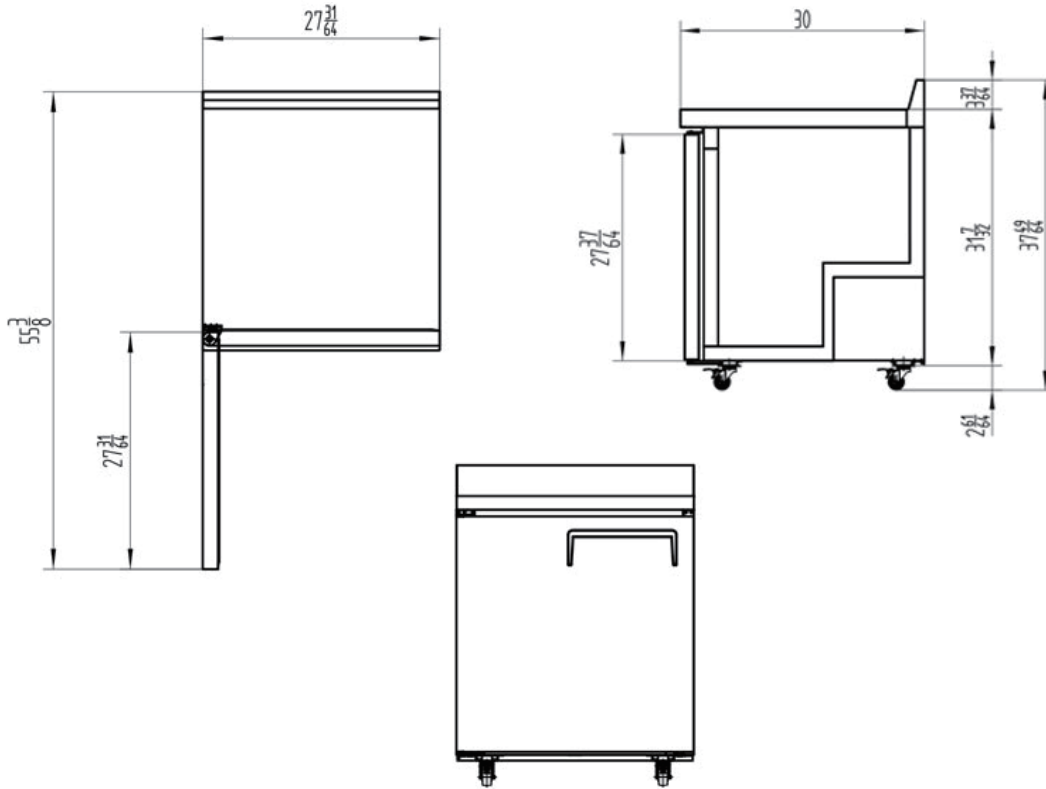

Model	Refrigerant	Doors	Shelves	Dimension (mm) (inch)			HP	Voltage	Amps	Capacity (L) (Cu Ft.)	Net Weight (KG) (LBS)	Temperature Range
				L	D	H						
CWDR1-27VC-L	R290	1	1	698	762	995	1/6	115/60	2.3	202	63	1 ~ 8°C
				27.5	30.0	39.2						

Equipped with one NEMA 5-15P plug 

**Shipping Information**

Crate Dimensions (mm) (inch)			Net Weight (KG) (LBS)	Gross Weight (KG) (LBS)
L	D	H		
752	831	1077	65	80
29.6	32.7	42.4	137	176

Specifications subject to change without notice.