



**BEVERAGE-AIR®**

PROJECT: \_\_\_\_\_  
 ITEM # \_\_\_\_\_ QTY: \_\_\_\_\_  
 MODEL # \_\_\_\_\_  
 AIA # \_\_\_\_\_ SIS # \_\_\_\_\_  
 APPROVED: \_\_\_\_\_

**TOP MOUNT CROSS TEMP®**

**Model: CT2HC-1S**

**SOLID DOOR / REACH-IN REFRIGERATOR/FREEZER**



**7 YEAR WARRANTY  
 Parts, Labor, and Compressor**

**CABINET CONSTRUCTION**

- Exterior is stainless steel front with continuous coil coated sides
- Interior liner is made of corrosion resistant aluminum
- Door locks
- Expansion valve technology
- Easily converts from refrigerator to freezer
- Double cabinet configurable to all menu initiatives, temperature range of -15 to 40° F
- Modulates coil temp to achieve desired set point
- Intuitive compressor
- Quicker pull-down
- Improved product stability
- Rapid recovery defrost
- Six (6) epoxy coated shelves
- Field-reversible doors
- 6" Casters with (2) brakes



**OPTIONS & ACCESSORIES**

- Stainless steel exterior tray slide (kit #4)
- Stainless steel interior
- Stainless steel tray (A)
- Universal tray slide (AC)
- Epoxy coated wire rod
- Additional shelves
- Left hand hinged
- 3" Casters
- 6" Flanged legs

**REFRIGERATION SYSTEM**

- Uses environmentally friendly, energy efficient R290 refrigerant, and meets all regulatory requirements for CARB, SNAP, DOE & more
- Variable speed compressor technology achieve 30% more energy efficiency
- Adaptive defrost
- Epoxy coated evaporator coil



# BEVERAGE-AIR®

**Cross Temp®**  
**Model: CT2HC-1S**

PLAN VIEW

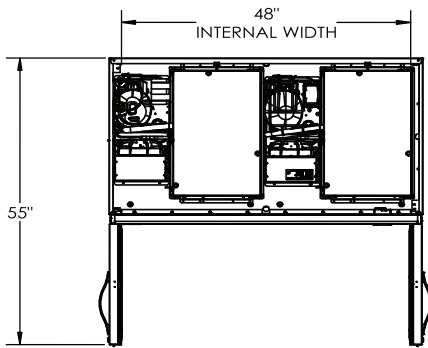

ELEVATION VIEW

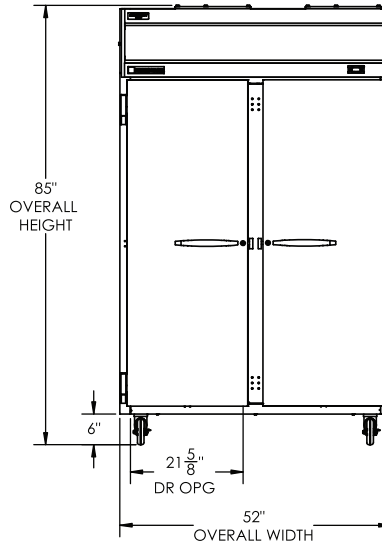

SIDE VIEW

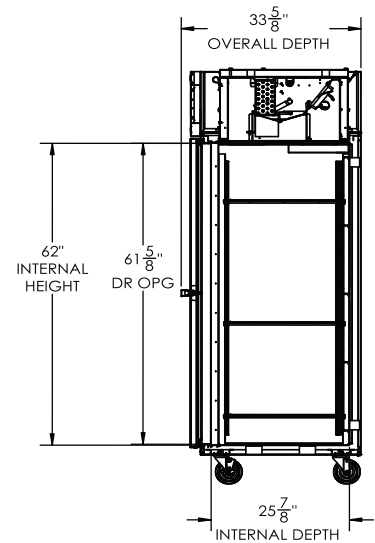

EXTERNAL DIMENSIONAL DATA	
Width Overall (in)	52"
Depth Overall (in)	33 5/8"
Height Overall (in)	85"
Number of Doors	4
Depth with Door open 90° (in)	55"
Door Openings (in)	21 5/8" x 61 5/8"
INTERNAL DIMENSIONAL DATA	
NET Capacity (cubic ft.)	45.2
Internal Width Useable (in)	48"
Internal Depth Overall (in)	25 7/8"
Internal Height Overall (in)	62"
Number of Shelves	6

ELECTRICAL DATA	
Full Load Amps	13.2
Voltage	115/60/1 *
Nema Plug (8' cord)	(2) 5-20P
REFRIGERATION DATA	
Horsepower	(2X) 4/5
Capacity (BTU/Hr)	(2X) 1970 - 4950
Heat Rejection (BTU/Hr)	(2X) 2955 - 7425
Charge (lbs/grams/ounces)	(2X) 0.286 / 130 / 4.58
SHIPPING DATA	
Gross Weight - Crated	540 lbs.
Height - Crated (in)	88"
Width - Crated (in)	55"
Depth - Crated (in)	36"

We reserve the right to change specifications and product design without notice. Such revisions do not entitle the buyer to corresponding changes, improvements, additions or replacements for previously purchased equipment. Dimensional tolerances +/- 1/4". Metric dimensions (MM).

\* NOTE: Units that utilize variable speed compressor technology can experience nuisance tripping on Class A GFCI outlets which have a trip limit of 4 to 6 mA. To avoid this issue in a location that requires GFCI circuit protection, Beverage-Air recommends using either an Eaton, SGF20, or HUBBELL Model Number GFRST83W 20A Heavy Duty Hospital Grade Self-Test GFCI Receptacle.

Required Clearance: Top 12" & Rear 3"

### ELECTRICAL CONNECTION



115/60/1  
5-20P

Unit pre-wired at factory and include (2) 8' long cord and plug set.

3779 Champion Blvd., Winston-Salem, NC 27105 | 888-845-9800 | Fax: 336-245-6453 | Beverage-Air.com | Sales@bevair.com

Date Issued 9/25 | Printed in U.S.A.