



Equipment for the Foodservice Industry

value + quality + service

## Salad/Sandwich Prep Tables

CSDR2-60CC



### CSDR2-60CC

### Features

Features:

- High quality stainless steel cabinets
  - Features 24 gauge, Type 304 stainless steel interior walls, doors and bottom shelf. Features 24 gauge, Type 430 stainless steel exterior sides and doors
- Lid allows easy access to food
- Polyethylene cutting board
- Self-closing swing door w/90° stay open feature
- Recessed handles
- Removable gasket that is easy to clean and replace
- Adjustable/removable plastic coated wire shelves
- Enclosed condiment section
- Foamed-in polyurethane cell insulation
- Auto evaporation of defrosting water
- Insulated lids on prep units helps to maintain food freshness
- Mechanical control of temperature
- Round corner design for inner bottom board
- Casters for easy movement
- Cold air circulation via fan for temperature balance
- Condenser access at rear of unit, slides out for easy maintenance

Warranty:

- 2 year parts and labour; 5 years on compressor
- Specifications subject to change without notice.



**CSDR2-60CC**

**Specifications**

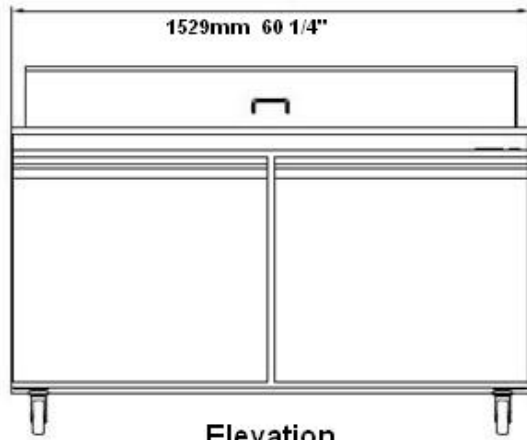

**Elevation**

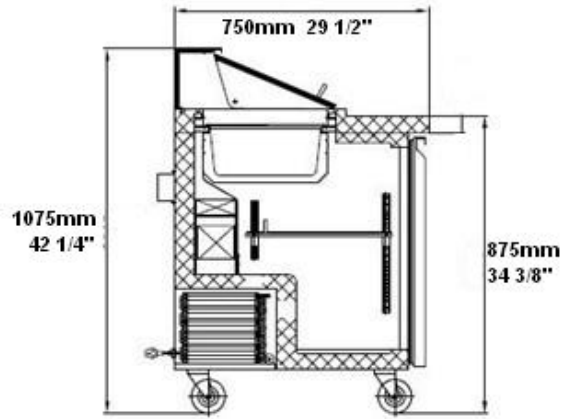

**Section View**

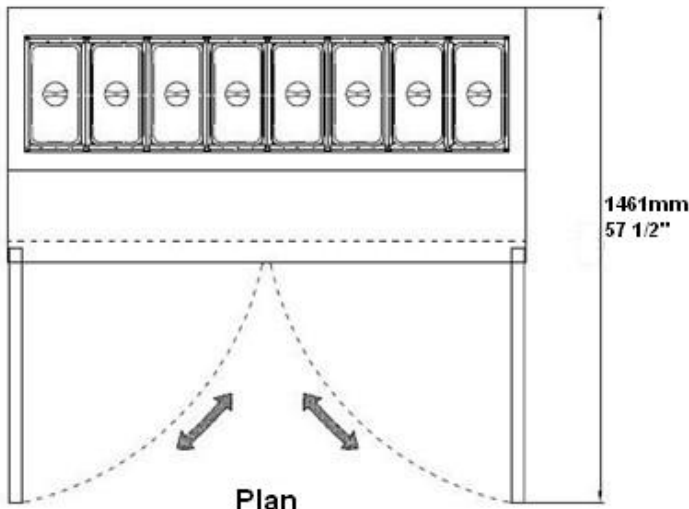

**Plan**

Model	Doors	Shelves	Dimension (mm) (inch)			HP	Voltage	Amps	Capacity (L) (Cu Ft.)	Net Weight (KG) (LBS)	NEMA Config.
			L	D	H						
CSDR2-60CC	2	2	1531.6	749.3	1074.4	1/4+	115/60/1	4.8	424.8	145.2	5-15P 
			60.3	29.5	42.3						