



# CR110A

## 110" Low-Profile Refrigerated Chef Base



CR110A  
08/04/23  
Item # 13493

### W x D x H

110.5" x 32.25" x 26"\*  
\*to work surface with 4" casters

Item #: \_\_\_\_\_

Project: \_\_\_\_\_

Qty: \_\_\_\_\_

AIA#: \_\_\_\_\_



## Features

- ▶ Heavy duty 16 gauge stainless steel top with marine edge (front/rear), drip edge (sides)
- ▶ Ceramic heat shield integral to top protects food from high heat
- ▶ 1500 pound capacity provides sturdy base for cooking equipment

- Environmentally friendly R290 hydrocarbon refrigerant
- Stainless steel exterior front, sides and top
- Stainless steel interior sides and back with stainless steel interior floor
- Solid state digital controller with temperature alarms and LED display (Fahrenheit or Celsius)
- Cabinet and drawers are insulated with 2" CFC free foamed in place polyurethane
- Stainless steel exterior drawer with stainless steel interior
- Drawers will accommodate (3) 12" x 20" x 6" deep pans (pans by others)
- Drawer module frames, acetal rollers and drawer stops are formed of heavy duty stainless steel all welded construction and securely fastened in the cabinet
- Drawers are equipped with finger cut-outs for easy removal of pans
- Extruded aluminum flush mount drawer handles
- Magnetic drawer gasket is easily removable for cleaning
- Removable stainless steel end panel for access to refrigeration system
- E-coated evaporator coil
- Energy efficient automatic hot gas condensate evaporator
- Standard with (8) 4" casters all with brakes
- 10 ft. cord and plug



### Dimensions / Capacity

	Two-Section CR110A
Interior Storage Capacity (CF)	24.75 ft <sup>3</sup>
Interior Storage Capacity (CF) (AHAM)	22.2 ft <sup>3</sup>
Overall Width x Depth (including 1" bumper)	110.5" x 33.25"
Overall Height (including 4" casters)	27"
Height To Work Surface (including 4" casters)	26"
Depth with Drawer Fully Open (including 1" rear bumper)	55.75"
Drawer Opening Width	38.5"
Pan Capacity (12" x 20") / per drawer	12 total / 3 per drawer
Maximum Pan Depth	6"
Maximum Load Capacity	1500 lbs.
Crated Shipping Weight	595 lbs.
Crated Length x Width x Height	112" x 34.5" x 30.5"

### Electrical / Refrigeration

	Two-Section CR110A
Voltage	115/60/1
HACR Breaker	15.0 Amps
Electrical Connection (NEMA)	5-15P
Voltage Range	104-126
Ambient Temp. Range	45° to 100°F
Control Setpoint Range	32° to 52°F
Amperage	3.0
Energy Consumption (kWh/day) @NSF	3.69
Heat Rejection (BTU/Hr.) @NSF	525
Approx. Nominal Compress. BTU/HR (HP)	1354(1/5HP)
Refrigerant / Charge Amount (oz)	R290(4.2 oz)

### Options

- HS-4007 - Drawer divider bars
- HS-5180 - Condenser Filter



Valid in United States, Canada, Puerto Rico and U.S. Territories. Contact factory for warranty in other countries.

Hoshizaki reserves the right to change specifications without notice.



# CR110A

## 110" Low-Profile Refrigerated Chef Base



CR110A  
08/04/23  
Item # 13493

### FRONT VIEW

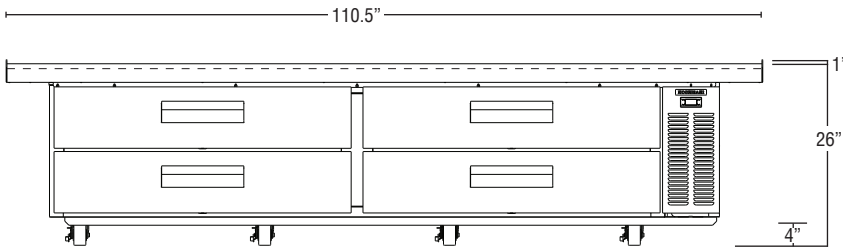

### SIDE VIEW

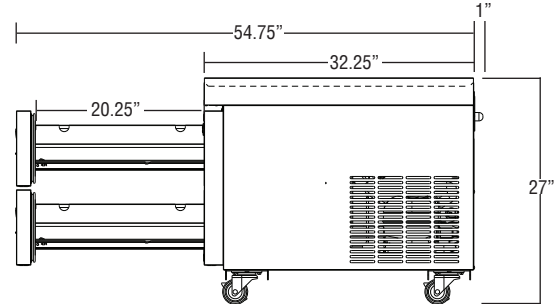

### PLAN VIEW

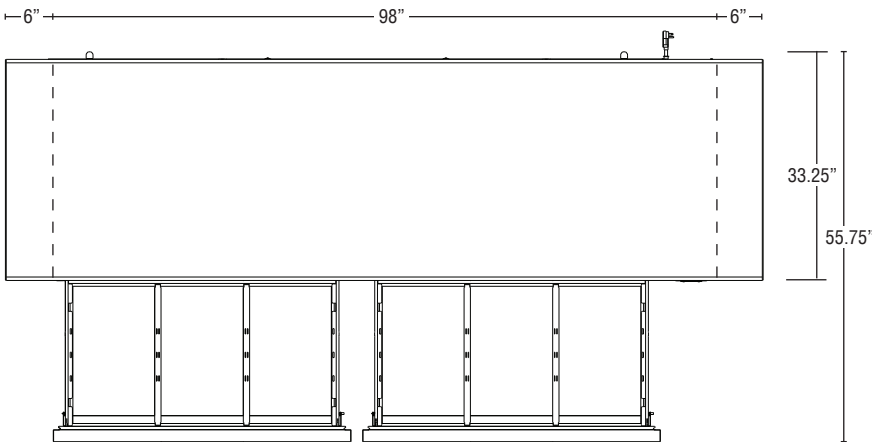

### CLEARANCES

- Top: A minimum of 4" (11cm) clearance is required between the bottom of the cooking equipment heating element and the appliance top. Temperature at the appliance top must not exceed 180°F (82°C).
- Sides: 1" (25mm) clearance
- Rear: The factory installed rear bumpers must be in place to ensure proper rear clearance.

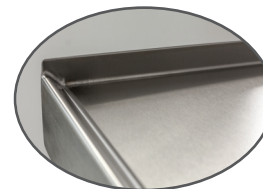

16 gauge stainless steel top with built in heat shield and 1" drip edge

### Cabinet Construction

The exterior cabinet front, sides, and top are constructed of high quality stainless steel. The exterior back and bottom are constructed of coated steel. The cabinet interior walls and ceiling are stainless steel. The floor is constructed of heavy gauge stainless steel with coved corner construction. Heavy duty ABS thermal breaks are used to reduce heat transfer in the frames. Cabinet walls and drawers are insulated with 2" of environmentally friendly CFC free, foamed in place polyurethane. 4" heavy duty platform casters (all with brakes) are standard and installed at the factory.

### Drawer Construction

Drawer fronts are constructed of high grade stainless steel with stainless steel interior and are insulated with CFC free, foamed in place polyurethane. Each drawer accommodates (3) 12" X 20" X 6" deep pans (pans by others). (Drawers will also accept 1/2, 1/3<sup>rd</sup> and 1/6<sup>th</sup> size pans with optional adapter bars). Drawer module frames are formed of heavy duty stainless steel all welded construction and securely fastened in the cabinet. The drawer slides are constructed of heavy duty stainless steel with durable acetal rollers with stainless steel ball bearings to prevent metal to metal contact. The drawer slides have been life tested (fully loaded) three hundred thousand cycles without showing significant wear. The flush mount handles are constructed of extruded aluminum. Snap-in magnetic drawer gaskets are durable and easily removed for cleaning.

### Refrigeration System

Solid state digital controller with temperature alarms maintains optimum cabinet temperature. A LED display shows the cabinet temperature and is adjustable to Fahrenheit or Celsius. The CR110A has a front breathing refrigeration system. The high efficiency refrigeration system is standard with an E-coated evaporator for extended life. Condensate removal is accomplished with an energy efficient hot gas condensate evaporator system. A capillary tube controls the flow of environmentally friendly R290 refrigerant through the evaporator. Refrigeration system utilizes an automatic, time-initiated, heated defrost to eliminate any ice on the evaporator coil. 115 volt units are equipped with a ten foot cord and plug (20.0 amps or less).