



Equipment for the Foodservice Industry

value + quality + service

Mega-Top Prep Table

CMDR2-60VC



CMDR2-60VC

Features

Features:

- Front breathing, side mount compressor
- Exterior & interior stainless steel construction
- Environmentally friendly R290 refrigerant
- Heavy duty Embraco compressor
- Self-closing and stay open door
- Efficient refrigeration system
- Recessed door handle
- Standard safety door lock
- Magnetic door gaskets
- Casters for easy movement
- Pre-installed shelves

Warranty:

- Two year parts and labour; Five years on compressor. For full warranty details visit <https://www.efifoodequip.com/warranty-info.php>



CMDR2-60VC Specifications

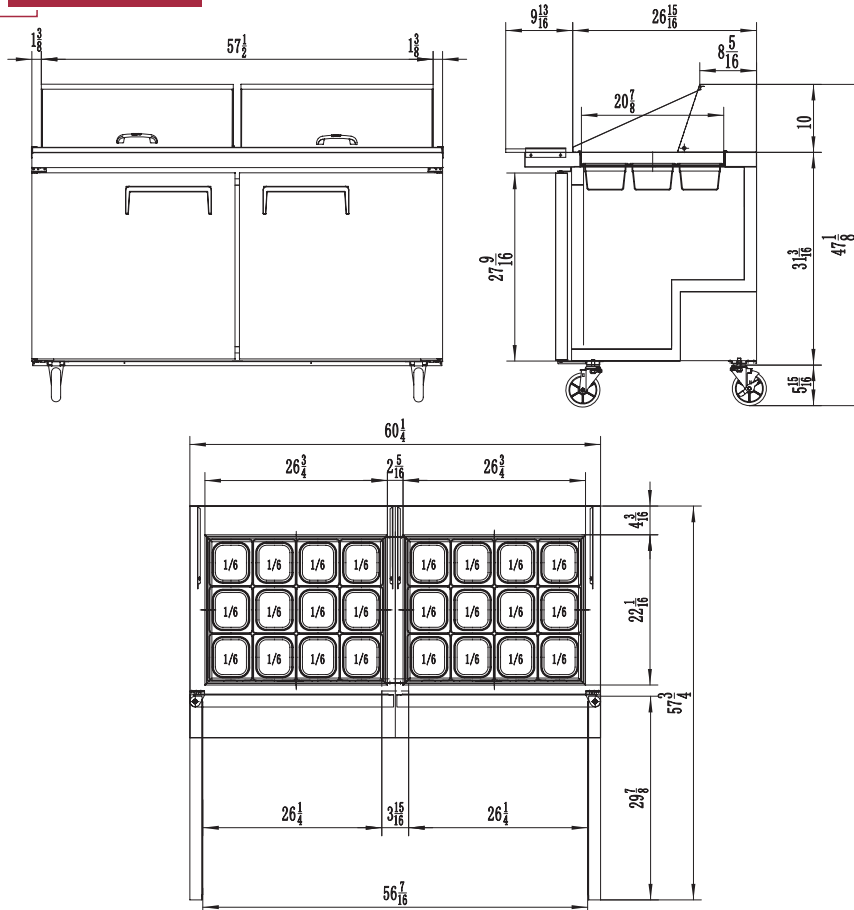

Model	Refrigrant	Doors	Shelves	Dimension (mm) (inch)			HP	Voltage	Amps	Capacity (L) (Cu Ft.)	Net Weight (KG) (LBS)	Temperature Range
				L	D	H						
CMDR2-60VC	R290	2	2	1530	863	1183	1/5	115/60	2.8	586	129	1 ~ 8°C
				60.2	34.0	46.6				20.7	284	33 ~ 45°F

Equipped with one NEMA 5-15P plug 

Shipping Information

Crate Dimensions (mm) (inch)			Net Weight (KG) (LBS)	Gross Weight (KG) (LBS)
L	D	H		
1585	932	1247	129	154
62.4	36.7	49.1	284	340

Specifications subject to change without notice.