

efi sales Ltd.

Equipment for the Foodservice Industry
value + quality + service

Countertop Display Case 60" - 252L

Model No:
CGCM-CT-6027-4



CGCM-CT-6027-4 Features

Features:

- Stainless steel exterior & interior with black frame
- Rear mount compressor with environmentally friendly R290 refrigerant
- Digital temperature controller
- Two (2) adjustable chrome plated shelves
- Defog feature to ensure the glass stays clear
- Maintains temperatures between 0 ~ 12°C / 32°F ~ 53.6°F
- Front curved glass
- Rear sliding glass doors for easy access
- LED interior lighting
- Leveling legs

Warranty:

- Two year parts and labour; Five years on compressor. *For full warranty details visit <https://www.efifoodequip.com/warranty-info.php>*



CGCM-CT-6027-4 Specifications

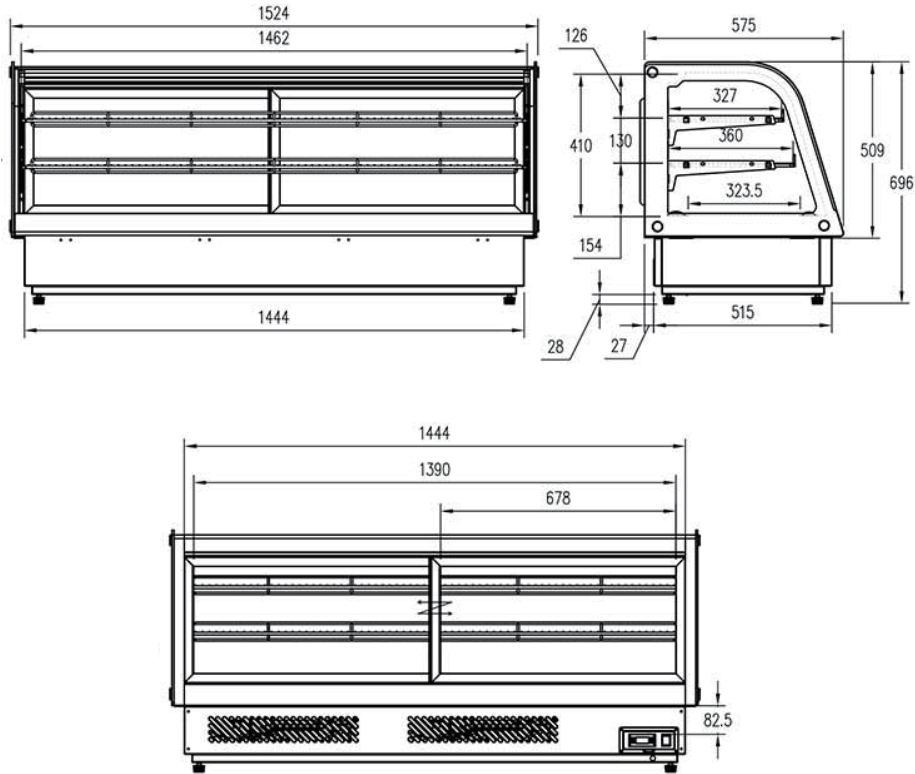

Model	Refrigerant	Shelves	Dimension (mm / inch)			Voltage	Amps	Capacity (L) / (Cu Ft.)	Net Weight (kg) / (lb)	Temperature Range
			W	D	H					
CGCM-CT-6027-4	R290	2	1524	575	696	110/60	5	252	121.5	0 ~ 12°C
			60	22.6	27.4			8.9	267.9	32 ~ 53.6°F

Equipped with one NEMA 5-15P plug 

Shipping Information

Crate Dimensions (mm / inch)			Net Weight (kg) / (lb)	Gross Weight (kg) / (lb)
W	D	H		
1595	627	734	121.5	140.5
62.8	24.7	28.9	267.9	309.7

Specifications subject to change without notice.