

efi sales Ltd.

Equipment for the Foodservice Industry
value + quality + service

Countertop Display Case 48" - 202L

Model No:
CGCM-CT-4827-4



CGCM-CT-4827-4 Features

Features:

- Stainless steel exterior & interior with black frame
- Rear mount compressor with environmentally friendly R290 refrigerant
- Digital temperature controller
- Two (2) adjustable chrome plated shelves
- Defog feature to ensure the glass stays clear
- Maintains temperatures between 0 ~ 12°C / 32°F ~ 53.6°F
- Front curved glass
- Rear sliding glass doors for easy access
- LED interior lighting
- Leveling legs

Warranty:

- Two year parts and labour; Five years on compressor. For full warranty details visit <https://www.efifoodequip.com/warranty-info.php>



CGCM-CT-4827-4 Specifications

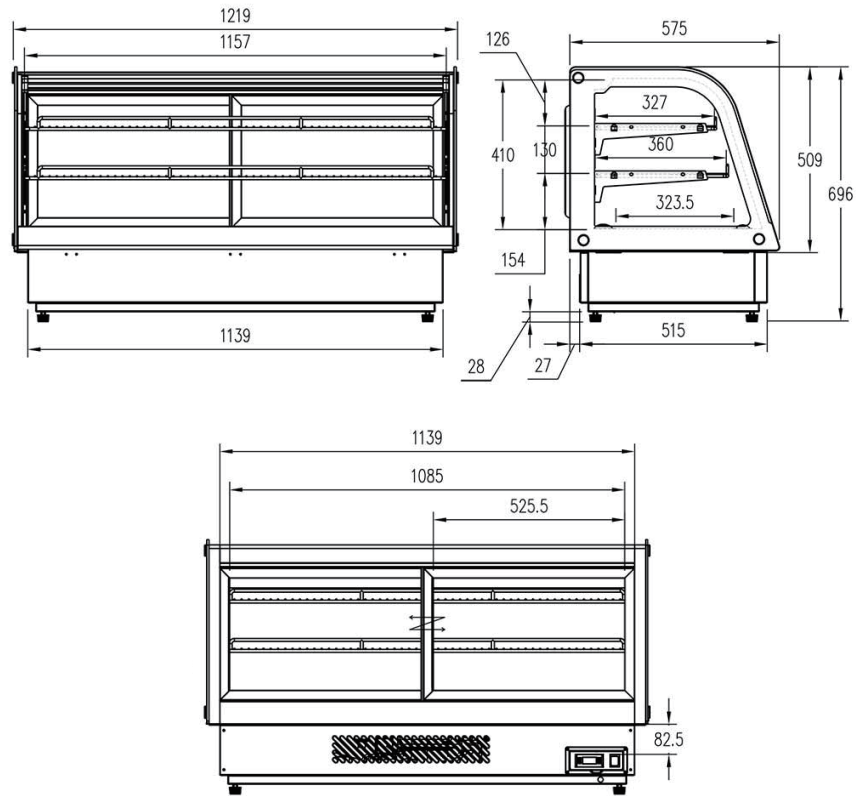

Model	Refrigerant	Shelves	Dimension (mm / inch)			Voltage	Amps	Capacity (L / Cu Ft.)	Net Weight (kg / lb)	Temperature Range
			W	D	H					
CGCM-CT-4827-4	R290	2	1219	575	696	110/60	3.9	202	93.5	0 ~ 12°C
			48	22.6	27.4			7.1	206.1	32 ~ 53.6°F

Equipped with one NEMA 5-15P plug 

Shipping Information

Crate Dimensions (mm / inch)			Net Weight (kg / lb)	Gross Weight (kg / lb)
W	D	H		
1290	627	734	93.5	106
50.8	24.7	28.9	206.1	233.7

Specifications subject to change without notice.