

efi sales Ltd.

Equipment for the Foodservice Industry
value + quality + service

Countertop Display Case 35" - 160L

Model No:
CGCM-CT-3527-4



CGCM-CT-3527-4 Features

Features:

- Stainless steel exterior & interior with black frame
- Rear mount compressor with environmentally friendly R290 refrigerant
- Digital temperature controller
- Two (2) adjustable chrome plated shelves
- Defog feature to ensure the glass stays clear
- Maintains temperatures between 0 ~ 12°C / 32°F ~ 53.6°F
- Front curved glass
- Rear sliding glass doors for easy access
- LED interior lighting
- Leveling legs

Warranty:

- Two year parts and labour; Five years on compressor. For full warranty details visit <https://www.efifoodequip.com/warranty-info.php>



CGCM-CT-3527-4 Specifications

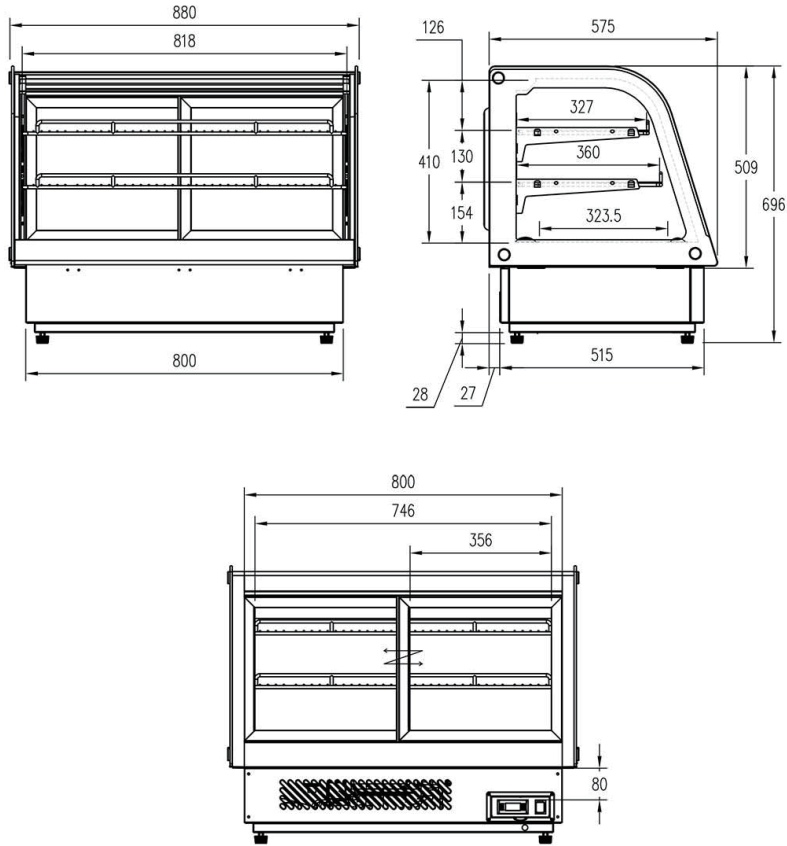

Model	Refrigerant	Shelves	Dimension (mm / inch)			Voltage	Amps	Capacity (L / Cu Ft.)	Net Weight (kg / lb)	Temperature Range
			W	D	H					
CGCM-CT-3527-4	R290	2	880	575	696	110/60	3	160	69.5	0 ~ 12°C
			34.6	22.6	27.4			5.7	153.2	32 ~ 53.6°F

Equipped with one NEMA 5-15P plug 

Shipping Information

Crate Dimensions (mm / inch)			Net Weight (kg / lb)	Gross Weight (kg / lb)
W	D	H		
950	627	734	69.5	73
37.4	24.7	28.9	153.2	160.9

Specifications subject to change without notice.