

**efi** sales Ltd.

Equipment for the Foodservice Industry  
value + quality + service

## COUNTERTOP GLASS DOOR REFRIGERATOR

C1-21GDCT-L



### C1-21GDCT-L Features

Features:

- 21 L countertop display refrigerator with light box
- Tempered glass door for maximum product visibility
- Black exterior with white interior
- Digital temperature control
- Adjustable temperature range between 0°C - 10°C

- LED interior lighting
- Adjustable shelf

Warranty:

- One year parts and labour; Five years on compressor. For full warranty details visit <https://www.efifoodequip.com/warranty-info.php>



**C1-21GDCT-L Specifications**

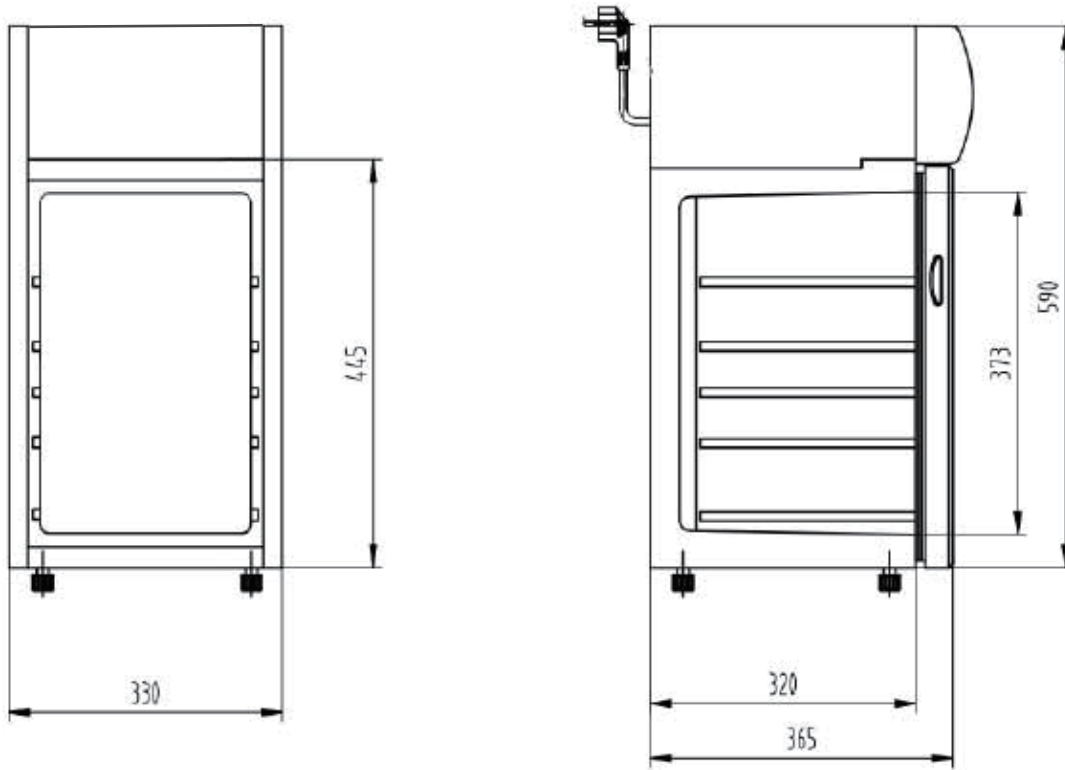

Model	Refrigrant	Door Type	Shelves	Dimension (mm) (inch)			Voltage	Power	Capacity	Net Weight (KG) (LBS)	Temperature Range
				W	D	H					
C1-21GDCT-L	R600a	Swing	2	330	406	615	110/60	76 W	21 L	16	0 ~ 10°C
				13.0	16.0	24.2				35.2	32 ~ 50°F

Equipped with one NEMA 5-15P plug 

**Shipping Information**

Crate Dimensions (mm) (inch)			Net Weight (KG) (LBS)	Gross Weight (KG) (LBS)
W	D	H		
426	486	684	16	17.5
16.7	19.1	26.9	35.2	38.6

Specifications subject to change without notice.