



BRIKA

BRB-24

ROBUST DESIGN
HIGH QUALITY STAINLESS STEEL

RADIANT BROILER 24 INCHES

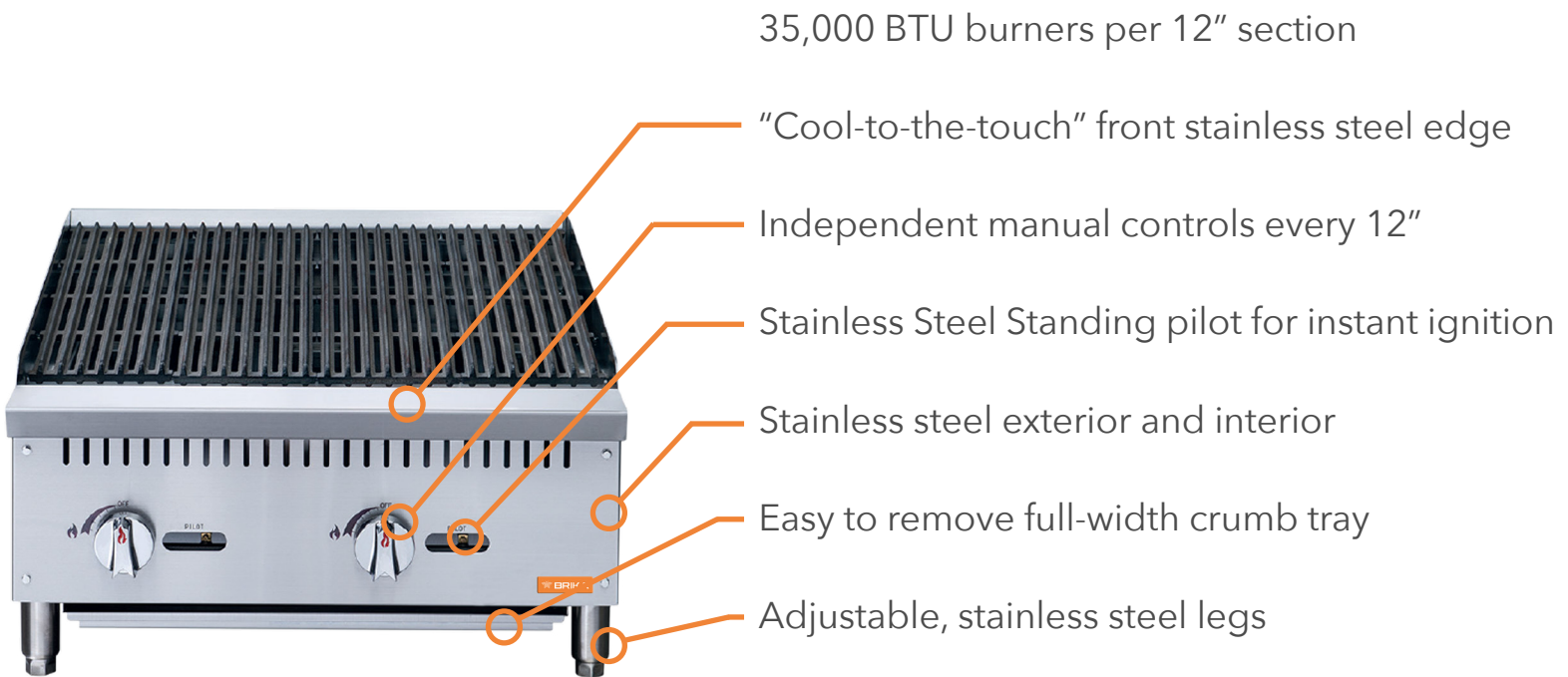

Dimensions (wxdxh) 24" x 28^{3/4}" x 15^{3/8}"

Cooking Area (wxd) 24" x 20^{1/2}"

Burners 2 x 35,000 BTU/H (total 70K)

BRB-24

DELIVERY

Box dimensions (w×d×h)

26^{1/8"} x 32^{5/8"} x 20^{1/2"}

Weight

net: 132 lbs

ship: 154 lbs

GAS POWERED

Natural	Source	Propane
4"WC	Pressure	10"WC
34#	Nozzle	49#

3/4" NPT **Connection** 3/4" NPT

if to be used above 2000 ft, specify altitude and gas type when ordering

FRONT VIEW

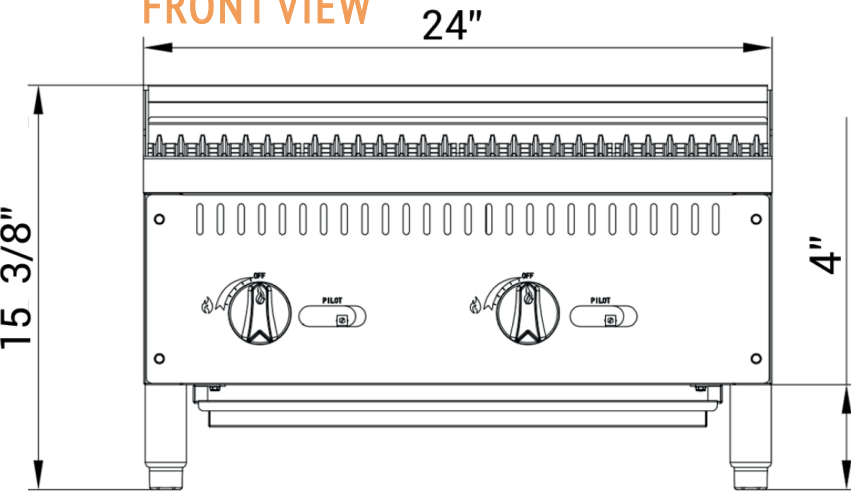

TOP VIEW

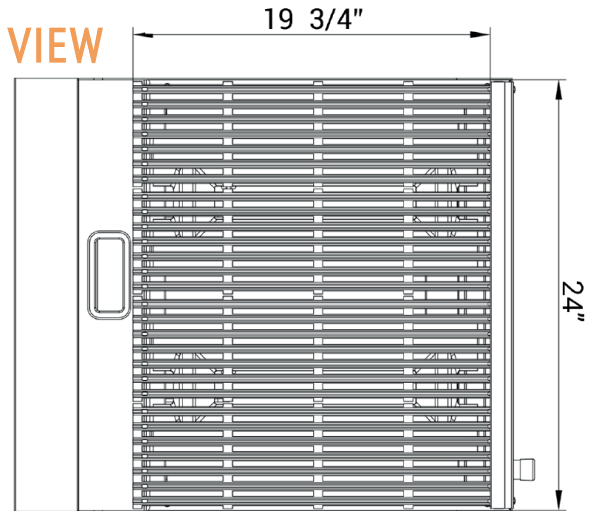

SIDE VIEW

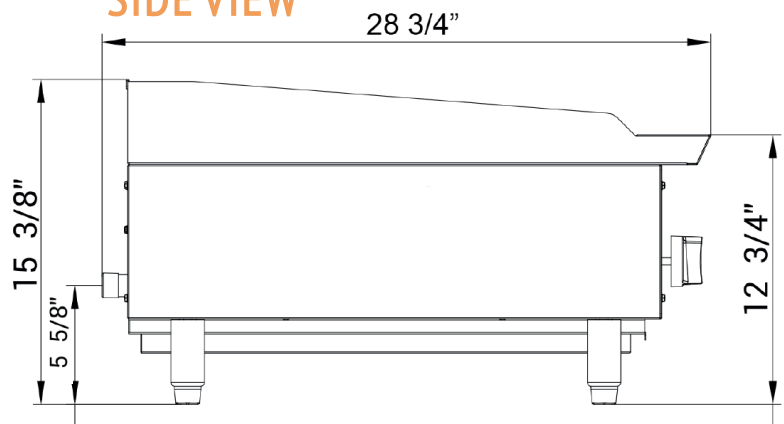

ASSEMBLY/SUPPORT



MORE PRODUCTS



SAFETY

Keep combustibles a minimum of 17" away from the equipment. Keep a clearance of 4" at the rear.

 We're on social media! 