



BRIKA

BGR-4B

GAS RANGE 4 BURNERS

ROBUST DESIGN
HIGH QUALITY STAINLESS STEEL



Stainless steel tubing for burners and pilot

Stainless steel exterior including front, sides, kick plate, back guard & over shelf

Heavy duty 12" X 12" removable cast iron top grates

Oven Temperature range between 175° & 500°F

Oven cooking area: 26"_w x 26"_d x 15"_h

Two (2) chrome oven rack per oven standard; 4 position oven rack guides.

Enamel interior oven for easy cleaning, with full width stainless steel crumb tray.

Fits bun pans either widthwise or lengthwise.

Optional caster wheels

Dimensions (wxdxh) 24" x 31^{1/2}" x 56"

Cooking Area (wxd) 24" x 24"

Burners LPG/NG: 1 x 30,000 BTU/H (OVEN)

LPG: 4 x 30,000 BTU/H (HOT PLATES)

NG: 4 x 33,000 BTU/H (HOT PLATES)

LPG TOTAL: 150K NG TOTAL: 162K

BGR-4B

DELIVERY

Box dimensions (wxdxh)

26" x 36^{4/5}" x 38^{1/5}"

Weight

net: 268 lbs

ship: 336 lbs

TOP VIEW

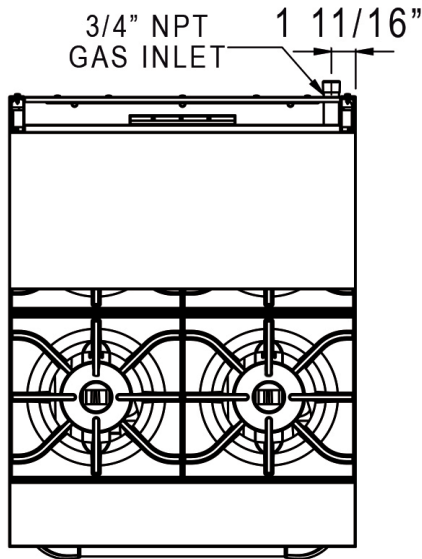

GAS POWERED

Natural Source Propane

5"WC Pressure 10"WC

40# Nozzle (OVEN) 52#

41# Nozzle (HOT P.) 52#

3/4" NPT Connection 3/4" NPT

if to be used above 2000 ft, specify altitude and gas type when ordering

SIDE VIEW

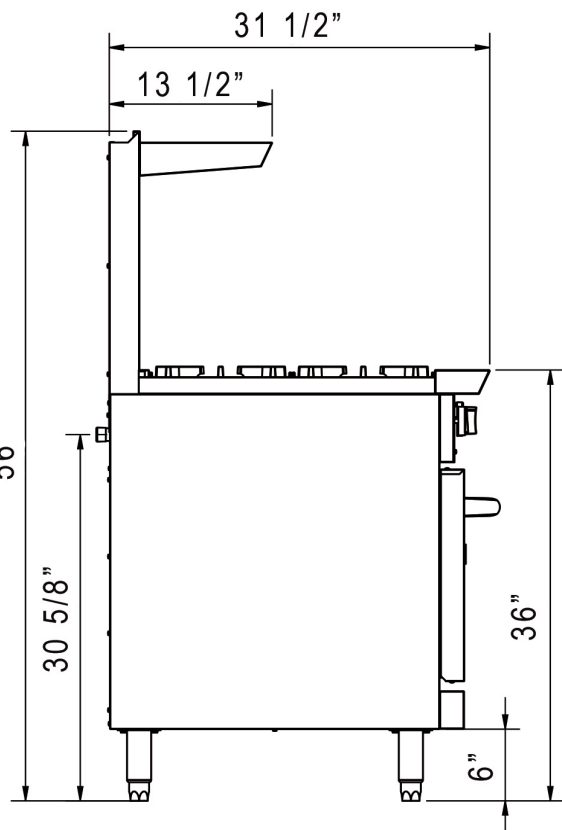

FRONT VIEW

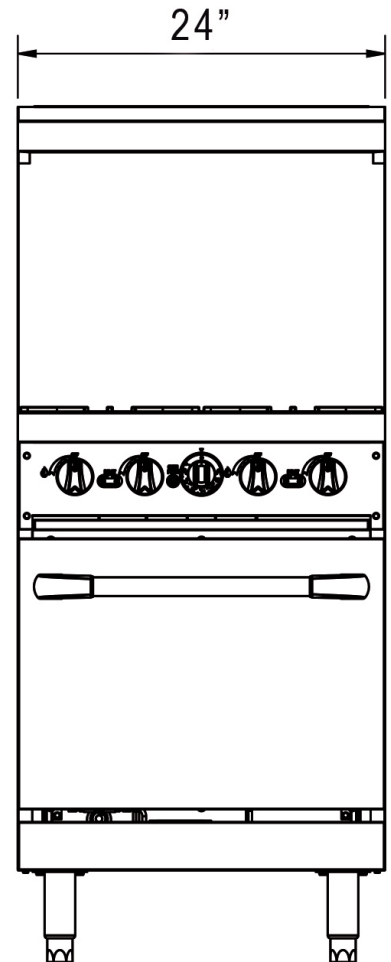

ASSEMBLY/SUPPORT



MORE PRODUCTS



SAFETY

Keep combustibles a minimum of 17" away from the equipment. Keep a clearance of 4" at the rear.

 We're on social media! 