



SERVING THE FOOD INDUSTRY SINCE 1951

Aurora 45-Inch Refrigerated Pizza Prep Table With Single Door

Item: 59042 Model: PT-CN-1270E-HC

MAIN FEATURES

- ▶ Durable and spacious
- ▶ High quality stainless steel 304
- ▶ CFC free refrigerant and foam
- ▶ Digital temperature controller and LCD display (Carel)
- ▶ Ventilated, automatic defrosting and evaporation of condensation water
- ▶ Adjustable heavy-duty PVC coated shelves
- ▶ Round interior corners for easy cleaning
- ▶ Self-closing doors fitted and durable door lock
- ▶ Castor with brake

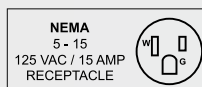

Authorized Dealer

Aurora 45" Refrigerated Pizza Prep Table Single Door



TECHNICAL DRAWINGS & DIMENSIONS

*measurements in diagrams are in mm

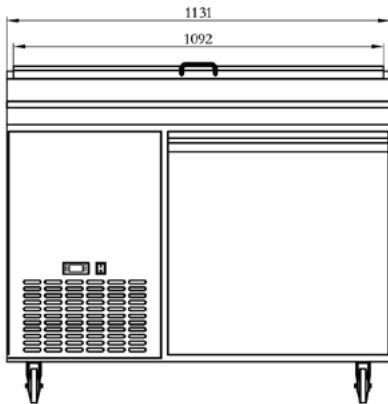

ELEVATION

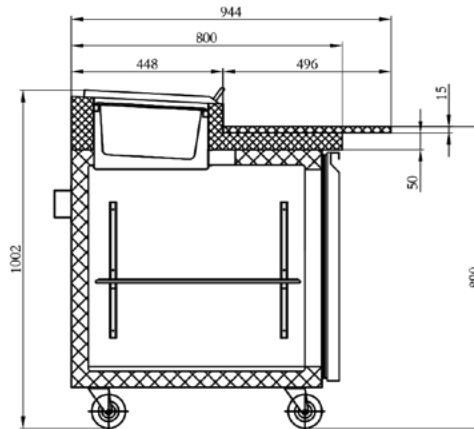

SECTION VIEW

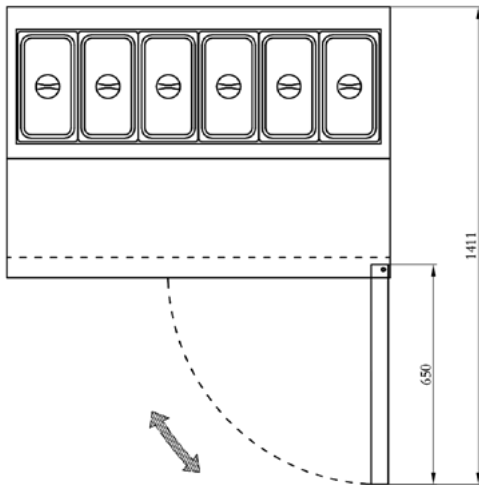

PLAN



TECHNICAL SPECIFICATIONS

Aurora 45" Refrigerated Pizza Prep Table with 1 Door

Item Number	59042
Model	PT-CN-1270E-HC
Net volume	7.8 cu. ft. / 220 L
Temperature Range	0.5°C - 4.4°C 33°F - 40°F
Refrigerant	R290
Electrical	110V / 60Hz / 1Ph
Power	336 W
Current	3.36 A
Isolation Material	Cyclopentane
Cooling System	Ventilated
Defrosting	Automatic
Number of Door	1
Number of Inserts	12 x 1/6 pans OR 6 x 1/3 pans
Number of Shelves	1
Shelf Material	Plastic Coated
Shelf Loading Capacity (Per PC)	88 lbs / 40 kg
Exterior Dimensions (WDH)	44.5" x 31.5" x 39.4" 1131 x 800 x 1002 mm
Interior Dimensions (WDH)	22.3" x 23.2" x 22.9" 566 x 590 x 582 mm
Net Weight	187 lbs / 85 kg
Gross Weight	264.6 lbs / 120 kg

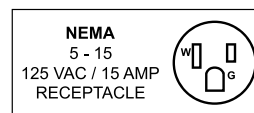

This equipment is intended for indoor environment using where

ambient temperature do not exceed **24°C / 75°F** & **55%** relative humidity

OMCAN INC.

Telephone: 1-800-465-0234

Fax: (905) 607-0234

Email: sales@omcan.com

Website: www.omcan.com

Follow us to keep up to date with the latest news and offers

